

Contents

1	General provisions	(1)
2	Terms	(2)
3	Basic requirements	(3)
4	Seismic checking	(4)
5	Horizontal vessel	(5)
5.1	General requirements	(5)
5.2	Earthquake effect and seismic checking	(6)
5.3	Seismic measures	(10)
6	Vertical vessels supported by legs	(11)
6.1	General requirements	(11)
6.2	Earthquake effect and seismic checking	(11)
6.3	Seismic measures	(12)
7	Vertical vessels supported by lugs	(13)
7.1	General requirements	(13)
7.2	Earthquake effect and seismic checking	(13)
7.3	Seismic measures	(13)
8	Vertical vessels supported by skirts	(15)
8.1	General requirements	(15)
8.2	Earthquake effect and seismic checking	(15)
8.3	Seismic measures	(19)
9	Spherical tanks supported by columns	(20)
9.1	General requirements	(20)
9.2	Earthquake effect and seismic checking	(20)
9.3	Seismic measures	(29)
10	Vertical cylindrical storage tanks	(30)
10.1	General requirements	(30)
10.2	Earthquake effect and seismic checking	(30)
10.3	Seismic measures	(31)
11	Heaters	(32)
11.1	General requirements	(32)
11.2	Earthquake effect and seismic checking	(32)
11.3	Seismic measures	(34)
12	Air-cooled heat exchangers	(37)
12.1	General requirements	(37)
12.2	Earthquake effect and seismic checking	(37)
12.3	Seismic measures	(41)
	Explanation of wording in this standard	(42)
	List of quoted standards	(43)

1 General provisions

1.0.1 This standard is prepared with a view to implement the *Law of the People's Republic of China on Protecting Against and Mitigating Earthquake Disasters* and carry out the policy of "prevention first", mitigate earthquake damage, reduce losses, appraise the seismic capability of in-service petrochemical equipment. It is prepared in order to provide a basis for seismic retrofitting or strategy for other seismic and disaster reduction also.

1.0.2 This standard is applicable to seismic appraisal of horizontal vessels, vertical vessel supported by legs, vertical vessel supported by lugs, vertical vessel supported by skirt, spherical tank, vertical cylindrical storage tank, heaters, air cooled heat exchangers and other equipment in petrochemical industry which are used in regions where the design basic acceleration of ground motion is not greater than 0.40g or seismic precautionary intensity is 9 degree or less.

1.0.3 The seismic precautionary objective established in this standard is that in case the in-service petrochemical equipment is subjected to earthquake action corresponding to the seismic precautionary intensity set for the region, it can remain in use without repair and without causing secondary disasters detrimental to personal and environmental safety.

1.0.4 The petrochemical equipment which does not experience seismic precaution or which cannot meet the seismic precautionary requirement shall be subject to seismic appraisal and provided with necessary seismic measures.

1.0.5 The design parameters of ground motion or the seismic precautionary intensity shall be determined in accordance with the current national standard GB 18306 *Seismic Ground Motion Parameters Zonation Map of China*. For the regions where the seismic precautionary zoning has been developed or the building sites where the seismic safety evaluation has been completed, the seismic appraisal may be carried out according to the approved design parameters of ground motion or seismic precautionary intensity.

1.0.6 In addition to this standard, the seismic appraisal of petrochemical steel vessel shall comply with the relevant current China's national standards.

2 Terms

2.0.1 Seismic precautionary criterion

A criterion that measures the seismic precautionary requirement, it shall be determined by the design parameters of ground motion or the seismic precautionary intensity and the importance of the equipment in service.

2.0.2 Design basic acceleration of ground motion

A design value of earthquake acceleration with a probability of exceedance being 10% over a 50 year design reference period shall be taken.

2.0.3 Seismic appraisal

A practice of evaluating the safety of the in-service equipment under the earthquake action according to the specified seismic precautionary requirement by checking the design, construction quality and service condition of the equipment.

2.0.4 Comprehensive seismic capability

The capability of equipment to withstand the earthquake action, which is determined by taking into account the factors of the structure and bearing capability.

2.0.5 Seismic retrofit

Design and construction activities which are carried out to enable the in-service equipment to meet the requirements of seismic appraisal.

2.0.6 Seismic measures

Seismic design contents except for calculation of earthquake action and resistance, which are basic requirements of seismic design and structural measures for seismic.

3 Basic requirements

3.0.1 The seismic appraisal shall involve the following activities and requirements:

1 Collect the original data such as the survey report, design documents, and as-built acceptance report of the construction site where the equipment is located. Where the data are incomplete, supplementary survey shall be carried out according to the needs for seismic appraisal;

2 Check the conformity of status of the equipment with the original data;

3 Use the appropriate appraisal method to analyze the seismic capability of the equipment comprehensively according to structural characteristics, layout and surrounding environment, etc;

4 For the equipment which cannot meet the seismic precautionary requirements through seismic appraisal, final solution shall be proposed according to the application requirement.

3.0.2 If required, seismic measures shall be comprehensively determined according to the characteristics of the equipment, the surrounding environment and other factors, and the measures shall be convenient implement so as to reduce the impact to production process.

3.0.3 The building(structure)and foundation where the equipment is mounted, and other facilities that may cause damage to the equipment shall meet the relevant seismic precautionary requirement.

3.0.4 When basic seismic acceleration is 0.05g or seismic precautionary intensity is 6 degree, it is not necessary to perform seismic checking. However, the requirements for seismic measures shall be met.

3.0.5 The on-site appearance inspection of the equipment shall include following items:

1 The equipment is unfixed or not;

2 The anchor bolts of the equipment are fastened with double nuts or with anti-loosening devices or not;

3 The main equipment is attached with accessory equipment or not;

4 The framework that supports the equipment is provided with bracings or not;

5 The equipment is placed on framework or not;

6 Flexible connection is used between equipment and large-size pipeline or not.

3.0.6 Except for air-cooled heat exchangers, the earthquake action on equipment in the area where it is mounted shall be determined according to the requirements of the current national standard GB/T 50761 *Standard for Seismic Design of Petrochemical Steel Equipments*.

3.0.7 The equipment that requires seismic appraisal shall be classified in terms of importance according to its application and degree of hazard after earthquake. The importance degree of equipment shall be classified according to the requirements of the current national standard GB/T 50761 *Standard for Seismic Design of Petrochemical Steel Equipments*.

3.0.8 The importance degree of framework of heater and air cooler shall be classified according to the requirements of the current national standard GB 50453 *Standard for Classification of Seismic Protection of Buildings and Special Structures in Petrochemical Engineering*.

4 Seismic checking

4.0.1 The earthquake action on the equipment that require seismic checking may be calculated according to the requirements of the current national standard GB/T 50761 *Standard for Seismic Design of Petrochemical Steel Equipments* or GB 50011 *Code for Seismic Design of Buildings*. For horizontal vessels and vertical vessels supported by legs installed on framework, the amplification of earthquake action contributed by the framework shall be taken into account.

4.0.2 Except for air-cooled heat exchangers, the allowable stress used for seismic appraisal of vessel materials shall be taken as 120% of the allowable stress for seismic design as specified in GB/T 50761 *Standard for Seismic Design of Petrochemical Steel Equipments*.

4.0.3 The effective thickness of cross-section of vessel subjected to seismic checking shall be determined as follows:

1 The effective thickness may be taken as the nominal thickness shown on the assembly drawing minus the additional thickness (i.e., corrosion allowance plus negative deviation of steel plate).

2 The effective thickness may be taken as the in-service examination data minus the corrosion allowance over the expected life time.

3 The effective thickness may be taken as the measured wall thickness minus the corrosion allowance over the expected life time. The quantity of test points shall be greater than 10. The wall thickness shall be calculated according to the following formulas:

$$t_s = \bar{X} - \sigma \quad (4.0.3-1)$$

$$\bar{X} = \frac{1}{n} \sum_{i=1}^n t_i \quad (4.0.3-2)$$

$$\sigma = \sqrt{\frac{1}{n} \sum_{i=1}^n (\bar{X} - t_i)^2} \quad (4.0.3-3)$$

Where:

t_s —measured wall thickness(mm);

\bar{X} —average of the measured wall thickness(mm);

σ —mean squared error of the measured wall thickness(mm);

n —quantity of points measured wall thickness;

t_i —measured wall thickness at the i^{th} point(mm).

5 Horizontal vessel

5.1 General requirements

5.1.1 The seismic appraisal of horizontal vessel on saddles (as shown in Figure 5.1.1-1 and Figure 5.1.1-2) shall comply with the requirements in this chapter.

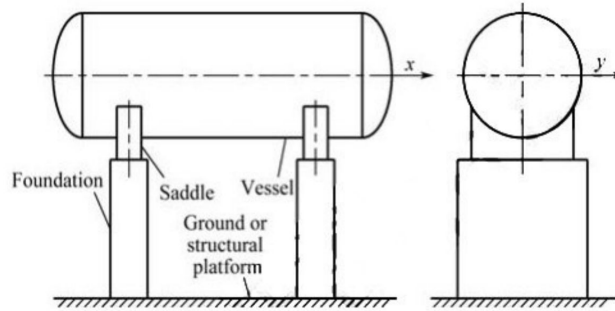

Figure 5.1.1-1 Horizontal vessel on saddles and its foundation

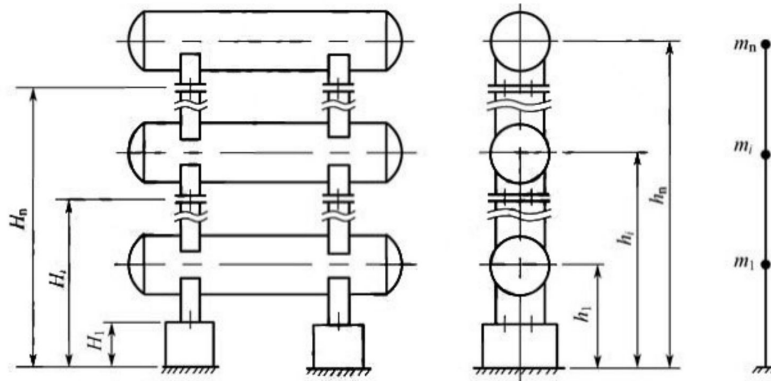

Figure 5.1.1-2 Stacked vessels on saddles and their calculation dimension

H_1, H_2, H_n —distance between saddle base plates of the vessels above ground and framework floor respectively (mm);

h_1, h_i, h_n —distance between centroids of vessels above ground and framework floor respectively (mm);

m_1, m_i, m_n —mass of vessels concentrated at point 1, i , n respectively (kg)

5.1.2 The appearance inspection of horizontal vessels that require seismic appraisal shall meet the following requirements:

1 The vessel shell shall be free of local deformation, the welds on the shell shall be fully filled and free of any surface defects;

2 The welds between the saddles and the vessel shell shall be fully filled and free of any surface defects;

3 The saddles shall not be tilted obviously; and the masonry or concrete supports shall not get loose or cracked or exposed steel bar;

4 Where the seismic precautionary intensity is 7 degree and above, strength connection shall be made between the vessel body and the support;

5 Measures shall be taken to prevent lateral movement of the sliding support;

6 The saddles shall be fixed with anchor bolts or connecting bolts which shall be anti-loosening.

5.1.3 Where the seismic precautionary intensity is 7 degree, for the horizontal vessels on ground with a

volume less than or equal to 2.5m^3 , the type and dimensions of the supports (Figure 5.1.3) shall meet the requirements in Table 5.1.3. The seismic checking may be exempted in any of the following cases:

- 1 In the case of steel saddle or steel saddle on concrete wall, the total height of the saddle and the foundation above the ground is less than or equal to 800mm;
- 2 In the case of masonry saddle or concrete saddle, the height of the saddle is less than or equal to 500mm.

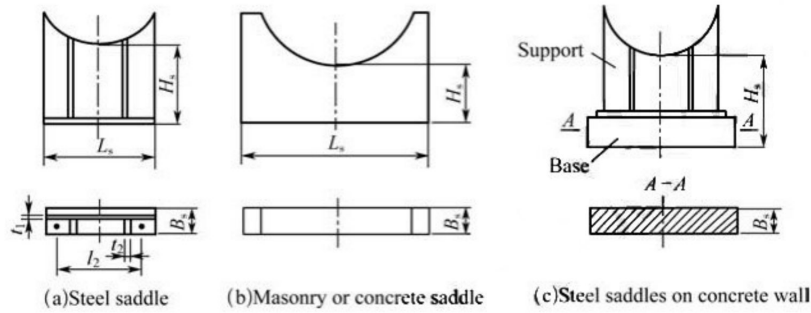

Figure 5.1.3 Types and dimensions of saddles

L_s —length of vessel saddle (mm)

Table 5.1.3 Standard dimensions of saddle of horizontal vessels (mm)

Type of support	Dimensions of saddle				
	$159 \leq DN < 500$	$500 \leq DN < 1500$	$1500 \leq DN < 2500$	$2500 \leq DN < 3000$	$3000 \leq DN \leq 4000$
Steel saddle	$B_s \geq 120$	$B_s \geq 160$	$B_s \geq 250$	$B_s \geq 300$	$B_s \geq 360$
	$t_1 \geq 6$	$t_1 \geq 10$	$t_1 \geq 12$	$t_1 \geq 16$	$t_1 \geq 20$
	$t_2 \geq 6$	$t_2 \geq 10$	$t_2 \geq 12$	$t_2 \geq 16$	$t_2 \geq 20$
Masonry saddle	$B_s \geq 240$	$B_s \geq 240$	$B_s \geq 370$	$B_s \geq 490$	$B_s \geq 620$
Concrete saddle	$B_s \geq 200$	$B_s \geq 300$	$B_s \geq 400$	$B_s \geq 500$	$B_s \geq 600$
Steel saddles on concrete wall	$B_s \geq 200$	$B_s \geq 250$	$B_s \geq 300$	$B_s \geq 350$	$B_s \geq 450$

Note: DN is nominal diameter, B_s is the support width, t_1 is the thickness of web plate, t_2 is the thickness of rib.

5.1.4 Where the seismic precautionary intensity is 7 degree, for the horizontal vessels on ground with a volume greater than 2.5m^3 , the type and dimensions of the supports (Figure 5.1.3) shall meet the requirement in Table 5.1.3. If ratio of H_s/L_s is less than or equal to 0.5, only the seismic checking need to be carried out for the support in any of the following cases:

- 1 In case of steel or concrete supports, H_s is less than or equal to 1.5m;
- 2 In case of masonry supports, H_s is less than or equal to 1.0m.

5.1.5 The earthquake action on horizontal vessels shall be calculated according to the requirements of the current national standard GB/T 50761 *Standard for Seismic Design of Petrochemical Steel Equipments*.

5.2 Earthquake effect and seismic checking

5.2.1 The equivalent support reaction on horizontal vessels subjected to earthquake action may be calculated according to following formula:

$$R = \frac{1}{n_z}(mg + F_V) + \frac{1}{n_z}F_H(H_1 - H_C)/l_2 \quad (5.2.1)$$

Where:

R —equivalent support reaction(N);

n_z —quantity of supports(piece);

m —operating mass of vessels(kg);

F_v, F_H —design values of horizontal and vertical earthquake action on vessels respectively, which may be calculated according to the requirements of current national standard GB/T 50761 *Standard for Seismic Design of Petrochemical Steel Equipments*(N);

H_c —height of concrete wall, which is taken as zero if the steel saddle is directly fixed onto the ground (mm);

l_2 —distance between anchor bolts located at opposite sides of axis of the cylinder (mm).

5.2.2 Where the saddle has no wear plate or the wear plate contribute no reinforcing effect on the shell of the horizontal vessel, the circumferential stress of the shell at the saddle edges(Figure 5.2.2) may be calculated according to following formulas:

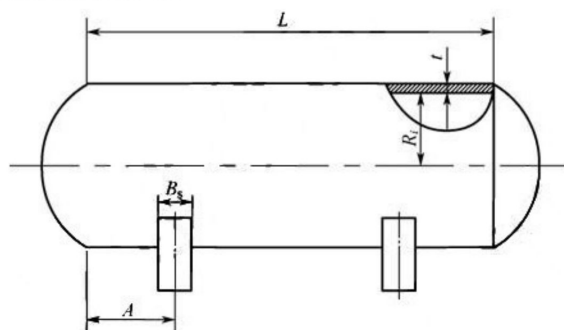

Figure 5.2.2 Calculation diagram of compressive stress on horizontal vessel

A —distance between centerline of support and tangent line of the head(mm);

R_s —inside radius of the shell(mm)

1 If $L/R_s \geq 8$, the following formula may be applied:

$$|\sigma| = \left| -\frac{R}{4t(B_s + 1.56 \sqrt{R_s t})} - \frac{3K_6 R}{2t^2} \right| \leq 1.25[\sigma] \quad (5.2.2-1)$$

2 If $L/R_s < 8$, the following formula may be applied:

$$|\sigma| = \left| -\frac{R}{4t(B_s + 1.56 \sqrt{R_s t})} - \frac{12K_6 R R_s}{L t^2} \right| \leq 1.25[\sigma] \quad (5.2.2-2)$$

Where:

L —distance between tangent lines of two heads(mm);

R_s —average radius of shell(mm);

σ —circumferential stress of the shell at the saddle edges(MPa);

t —effective thickness of the shell(mm);

B_s —width of the support; where the steel saddle is fixed on the concrete wall, the width of the steel saddle is taken(mm);

K_6 —coefficient, which is taken according to Table 5.2.2;

$[\sigma]$ —material allowable stress for seismic appraisal(MPa).

5.2.3 Where the wear plate contributes to reinforcing effect on the shell of the horizontal vessels, the circumferential stresses of the shell at the saddle edges and wear plate edges are calculated according to following formula:

Table 5.2.2 Coefficient K_6

A/R_a	Contact angle of saddle $\theta(^{\circ})$			
	120	135	150	165
≤ 0.5	0.0132	0.0103	0.0079	0.0059
≥ 1	0.0528	0.0413	0.0316	0.0238

Note: If $0.5 < A/R_a < 1$, K_6 shall be obtained by linear interpolation of the values in the table.

1 If $L/R_a \geq 8$, the following formulas may be applied:

$$|\sigma| = \left| -\frac{R}{4(t+t_r)(B_s+1.56\sqrt{R_a t})} - \frac{3K_6 R}{2(t^2+t_r^2)} \right| \leq 1.25[\sigma]^t \quad (5.2.3-1)$$

$$|\sigma'| = \left| -\frac{R}{4t(B_s+1.56\sqrt{R_a t})} - \frac{3K_6 R}{2t^2} \right| \leq 1.25[\sigma]^t \quad (5.2.3-2)$$

Where:

σ' —circumferential stress of the shell at the edges of wear plate of saddle(MPa);

t_r —effective thickness of wear plate(mm).

2 If $L/R_a < 8$, the following formulas may be applied:

$$|\sigma| = \left| -\frac{R}{4(t+t_r)(B_s+1.56\sqrt{R_a t})} - \frac{12K_6 R R_a}{L(t^2+t_r^2)} \right| \leq 1.25[\sigma]^t \quad (5.2.3-3)$$

$$|\sigma'| = \left| -\frac{R}{4t(B_s+1.56\sqrt{R_a t})} - \frac{12K_6 R R_a}{L t^2} \right| \leq 1.25[\sigma]^t \quad (5.2.3-4)$$

Note: In order to contribute to reinforcing effect of the wear plate, the following conditions shall be met simultaneously: t is greater than or equal to 60% of t_r ; the width of wear plate is greater than or equal to B_s ; the angle of contact of wear plate is at least 12° greater than that of the saddle.

5.2.4 The compressive stress of the steel saddle may be calculated according to the following formula:

1 Where the horizontal axial earthquake action is less than or equal to the static frictional force between the base plate of the saddle and the foundation ($F_H \leq mgf$), the following formula may be applied:

$$|\sigma_{sa}| = \left| -\frac{mg+F_v}{n_z A_{sa}} - \frac{F_H H}{2Z_r} - \frac{F_H(H_1-H_c)}{A_{sa}(L-2A)} \right| \leq [\sigma]_{sa} \quad (5.2.4-1)$$

2 Where the horizontal axial earthquake action is greater than the static frictional force between the base plate of the saddle and the foundation ($F_H > mgf$), the following formula may be applied:

$$|\sigma_{sa}| = \left| -\frac{mg+F_v}{n_z A_{sa}} - \frac{(F_H - F_f)H}{Z_r} - \frac{F_H(H_1-H_c)}{A_{sa}(L-2A)} \right| \leq [\sigma]_{sa} \quad (5.2.4-2)$$

Where:

f —coefficient of static friction between the base plate of saddle and the foundation, which is taken as 0.3 for steel base plate vs. steel pad of foundation; 0.4 for steel base plate vs. cement foundation; 0.1 for steel base plate vs. Teflon pad;

$|\sigma_{sa}|$ —compressive stress of steel saddle(MPa);

A_{sa} —combined cross-sectional area of web plate and rib (at the lowest point of cylinder or wear plate)(mm^2);

H —height of saddle(mm);

Z_r —section modulus in bending of combined cross-sectional area of web plate and rib (at the lowest point of cylinder or backing plate)(mm^3);

$[\sigma]_{sa}$ —allowable stress of saddle materials for seismic appraisal(MPa);

F —reaction force of each saddle(N);

f_s —coefficient of kinetic friction between the base plate of saddle and the base plate of foundation, which is taken as 0.15 for steel base plate vs. steel pad of foundation; 0.05 for steel base plate vs. Teflon pad.

5.2.5 The tensile stress of anchor bolts may be calculated according to following formula:

$$\sigma_{bt} = \frac{2F_H(H_1 - H_c)}{n_{bt}A_{bt}l_2} - \frac{mg - F_v}{n_{bt}A_{bt}} \leq [\sigma]_{bt} \quad (5.2.5)$$

Where:

σ_{bt} —tensile stress of anchor bolts(MPa);

n_{bt} —quantity of anchor bolts;

A_{bt} —cross-sectional area of each anchor bolt(mm²);

$[\sigma]_{bt}$ —allowable tensile stress of anchor bolts for seismic appraisal(MPa).

5.2.6 The shear stress of anchor bolts may be calculated according to the following formula:

$$\tau_{bt} = \frac{F_H}{n'_{bt}A_{bt}} \leq [\tau]_{bt} \quad (5.2.6)$$

Where:

τ_{bt} —shear stress of anchor bolts(MPa);

n'_{bt} —quantity of anchor bolts subjected to shear stress;

$[\tau]_{bt}$ —allowable shear stress of anchor bolts for seismic appraisal(MPa), which is taken as 0.8 $[\sigma]_{bt}$.

5.2.7 In the case of stacked vessels under earthquake action, the saddle reaction to the j^{th} vessel may be calculated according to the following formula:

$$R_j = \frac{1}{n_z} \sum_{i=j}^n (m_i g + F_{v_i}) + \frac{1}{n_z K_j} \sum_{i=j}^n F_i (H_i - h_j) \quad (5.2.7)$$

Where:

R_j —support reaction force to the j^{th} vessel(N);

m_i —concentrated mass of the i^{th} vessel(kg);

F_{v_i} —vertical earthquake action on the i^{th} vessel(N);

K_j —distance between bolts on support of the j^{th} vessel(mm);

F_i —horizontal earthquake action on the i^{th} vessel(N);

H_i —distance between centerline of the i^{th} vessel and the ground or floor(mm);

h_j —distance between bottom surface of support of the j^{th} vessel and the ground or floor(mm).

5.2.8 In the case of stacked vessels, the compressive stress in shell at the saddle edge may be calculated according to the requirements of Article 5.2.3 and Article 5.2.4.

5.2.9 In the case of stacked vessels, the tensile stress of connecting bolts of the saddle of the j^{th} vessel may be calculated according to following formula:

$$\sigma_{aj} = \frac{2}{n_{bj}A_{bj}K_j} \sum_{i=j}^n F_{H_i}(H_i - h_j) - \frac{1}{n_{bj}A_{bj}} \sum_{i=j}^n (m_i g - F_{v_i}) \leq [\sigma]_{bj} \quad (5.2.9)$$

Where:

σ_{aj} —tensile stress of connecting bolts of the saddle of the j^{th} vessel(MPa);

n_{bj} —quantity of connecting bolts of the saddle of the j^{th} vessel;

A_{bj} —effective cross-sectional area of one connecting bolt of the saddle of the j^{th} vessel(mm²);

K_j —distance between bolts of saddle of the j^{th} vessel(mm);

F_{H_i} —horizontal earthquake action on the i^{th} vessel(N);

H_i —distance between centerline of the i^{th} vessel and the ground or framework(mm);

h_j —distance between the bottom surface of saddle of the j^{th} vessel and the ground or framework (mm);

F_{v_i} —vertical earthquake action on the i^{th} vessel(N);

$[\sigma]_{bj}$ —allowable tensile stress for seismic appraisal of connecting bolts of saddle of the j^{th} vessel (MPa).

5.2.10 In the case of stacked vessels, the shear stress of connecting(anchor)bolts of the saddle of the j^{th} vessel may be calculated according to following formula:

$$\tau_j = \frac{1}{n'_{bj}A_{bj}} \sum_{i=j}^n F_i \leq [\tau]_{bj} \quad (5.2.10)$$

Where:

τ_j —shear stress of connecting bolts of the saddle of the j^{th} vessel(MPa);

n'_{bj} —quantity of anchor bolts subjected to shear stress;

$[\tau]_{bj}$ —allowable shear stress for seismic appraisal of connecting bolts of saddle of the j^{th} vessel (MPa).

5.3 Seismic measures

5.3.1 Where the seismic precautionary intensity is 7 degree or above, the vessel shall be fixed to the foundation using anchor bolts. The quantity of anchor bolts for each saddle shall be not less than 2.

5.3.2 Where the welds between the vessel body and the saddle can not meet the requirements, repair weld and strength weld shall be carried out, and the surface of welds shall be subject to non-destructive test.

5.3.3 In cases where masonry saddle or concrete saddle gets loose or cracked, reinforcing measures shall be taken.

5.3.4 In cases where the circumferential stress of the shell at the saddle edges can not meet the requirements, stiffening rings may be used.

5.3.5 The horizontal vessel fixed with anchor bolts shall be provided with anti-loosening device.

5.3.6 The sliding saddle which do not restrict lateral movement of vessels shall be provided with measures to restrict the movement.

6 Vertical vessels supported by legs

6.1 General requirements

6.1.1 The seismic appraisal of vertical vessels supported by legs (Figure 6.1.1) with a height not greater than 10m (including the height of legs) and a height/diameter ratio not greater than 5 shall meet the requirements of this chapter.

6.1.2 When seismic appraisal is required, the appearance of vertical vessels supported by legs shall meet the following requirements:

1 The welds between the legs and the shell shall be fully filled, and shall be free of cracks or other surface defects;

2 Each leg shall be fastened to the foundation with anchor bolts;

3 The legs shall not get deformed obviously;

4 Where the seismic precautionary intensity is 8 degree or above, and the diameter of the vessel is greater than 800mm, the quantity of legs should not be less than 4.

6.1.3 The seismic checking may be exempted for vertical vessels supported by legs in any of the following cases, but the requirements in Article 6.1.2 shall be met also:

1 The seismic precautionary intensity is 6 degree;

2 In the case of vertical vessels supported by legs which are installed on structures, their diameter is less than 1.0m, height is less than 2m (including the height of legs) and the height of legs is less than 0.5m, the seismic precautionary intensity is below 8 degree;

3 In the case of vertical vessels supported by legs which are installed on ground, the diameter is less than 1.2m, height is less than 3m (including the height of legs) and the height of legs is less than 0.5m, the seismic precautionary intensity is below 8 degree.

6.1.4 The seismic checking for vertical vessels supported by legs shall involve:

1 Strength checking and stability checking for legs;

2 Strength checking for anchor bolts;

3 Strength checking for connection welds of legs with shell.

6.1.5 The earthquake action on vertical vessels supported by legs shall be calculated according to the requirements of the current national standard GB/T 50761 *Standard for Seismic Design of Petrochemical Steel Equipments*.

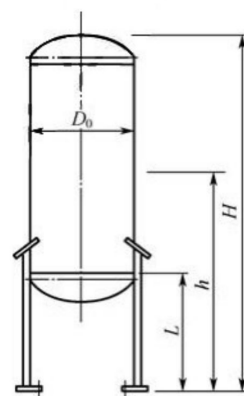

Figure 6.1.1 Vertical vessels supported by legs

6.2 Earthquake effect and seismic checking

6.2.1 The calculation of earthquake action effect and seismic checking of vertical vessels supported by legs shall be carried out according to the requirements of current national standard GB/T 50761 *Standard for Seismic Design of Petrochemical Steel Equipments*.

6.2.2 The allowable stress for seismic appraisal of vertical vessels supported by legs shall meet the

requirement of Article 4.0.2.

6.3 Seismic measures

6.3.1 Unfixed vertical vessels supported by legs shall be fastened to the foundation with anchor bolts.

6.3.2 When the seismic precautionary intensity is 8 degree and above and the quantity of legs is less than 4, reinforcing measures shall be taken for the legs.

6.3.3 If the seismic checking shows that the stability of legs can not meet the requirements, the legs shall be reinforced or diagonal bracings shall be provided between legs.

6.3.4 If the strength of anchor bolts can not meet the requirements, the size of anchor bolts shall be increased or other reinforcing measures shall be taken.

6.3.5 Where the weld joint between legs and the shell can not meet the requirements, repair welding shall be carried out and then the welds shall be subjected to non-destructive test.

6.3.6 Where the local stress of the region where legs connect to shell can not meet the requirements, local reinforcing measures shall be taken.

7 Vertical vessels supported by lugs

7.1 General requirements

7.1.1 The seismic appraisal of vertical vessels supported by lugs (Figure 7.1.1) shall meet the requirements of the chapter.

7.1.2 The appearance of vertical vessels supported by lugs that require seismic appraisal shall meet the following requirements:

- 1 The vessel shall not be unfixed;
- 2 The welds between the lugs and the vessel shell shall be fully filled, and shall be free of cracks or any other surface defects;
- 3 Where the diameter of the vessel is greater than 1m, the quantity of lugs shall be greater than 2;
- 4 Each lug shall be provided with anchor bolt and nut which shall be provided with anti-loosening devices also;
- 5 The lugs shall not be supported on masonry foundation.

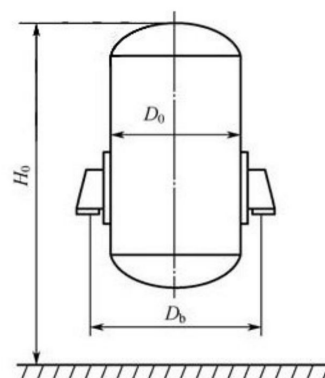

Figure 7.1.1 Vertical vessels supported by lugs

7.1.3 In the case of vertical vessels supported by lugs which have a diameter of less than 2m and distance between tangent lines of less than 5m, if the seismic precautionary intensity is less than 8 degree, seismic appraisal and checking may be exempted except the requirement in Article 7.1.2.

7.1.4 The seismic checking for vertical vessels supported by lugs shall involve:

- 1 Strength checking for lugs;
- 2 Strength checking for anchor bolts;
- 3 Strength checking for connection welds between lugs and cylinder;
- 4 Checking of local stress of cylinder at points where the cylinder joins the lugs.

7.1.5 The earthquake action on vertical vessels supported by lugs shall be calculated according to the requirements of the current national standard GB/T 50761 *Standard for Seismic Design of Petrochemical Steel Equipments*.

7.2 Earthquake effect and seismic checking

7.2.1 The calculation of earthquake action effect and seismic checking of vertical vessels supported by lugs shall be carried out according to the requirements of the current national standard GB/T 50761 *Standard for Seismic Design of Petrochemical Steel Equipments*.

7.2.2 The allowable stress for seismic appraisal of vertical vessels supported by lugs shall meet the requirement of Article 4.0.2.

7.3 Seismic measures

7.3.1 Where the appearance or strength of the connection welds between lugs and the cylinder can not meet the requirements, repair welding shall be carried out and the welds shall be subjected to non-destructive test.

7.3.2 Where the strength of lugs can not meet the requirements, the lugs shall be reinforced.

7.3.3 Where the local stress intensity of the cylinder at points where the cylinder join the lugs can not meet the requirements, pad plate shall be provided for purpose of reinforcing, or other measures shall be taken.

7.3.4 For unfixed vertical vessels supported by lugs, measures shall be taken to restrict movement.

8 Vertical vessels supported by skirts

8.1 General requirements

8.1.1 The seismic appraisal of vertical vessels supported by skirts shall comply with the requirements in this chapter.

8.1.2 The appearance of vertical vessels supported by skirts that require seismic appraisal shall meet the following requirements:

1 The connection welds between the shell and skirts shall be fully filled, and shall be free of any surface defect;

2 The cylinder shall not be severely corroded or get deformed.

8.1.3 The external piping, platform, stairs and main internals of vertical vessels supported by skirts shall be connected to the main body of the vessels firmly.

8.1.4 The appearance of anchor bolts that require seismic appraisal shall meet the following requirements:

1 The bolts shall not get deformed obviously, and the nuts shall not get loose. Double nuts shall be used, or anti-loosening devices shall be provided for the nuts.

2 Continuous welds shall be made for the joints between the ribs of the bolt chair and the skirt cylinder, cover plate and base ring. Where the spacing of ribs of the anchor bolt chair meets the requirement of Table 8.1.4, the checking of thickness of the base ring may be exempted.

Table 8.1.4 Spacing of ribs of anchor bolt chair (mm)

Bolt size	M24 to M36	M42 to M64	M72 to M90
Spacing of ribs	$\leq 4.0d$	$\leq 3.5d$ and ≤ 200	$\leq 3.0d$ and ≤ 250

Note: d is nominal diameter of anchor bolt.

8.1.5 The seismic appraisal of vertical vessels supported by skirts shall involve:

- 1 Strength checking for connection between skirt and shell;
- 2 Checking for anchor bolt chair.

8.1.6 The earthquake action on vertical vessels supported by skirts shall be calculated according to the requirements of the current national standard GB/T 50761 *Standard for Seismic Design of Petrochemical Steel Equipments*.

8.2 Earthquake effect and seismic checking

8.2.1 If base shear force method is used, the bending moment produced on any calculated cross-section $a-a$ due to horizontal earthquake action on the vertical vessels (Figure 8.2.1) may be calculated according to the following formula:

$$M_{Ea} = \sum_{i=k}^n F_{li}(h_i - h_a) \quad (8.2.1)$$

Where:

M_{Ea} —earthquake bending moment (N·mm) produced on any calculated cross-section $a-a$;

k —the first mass point number above the calculated cross-section $a-a$;

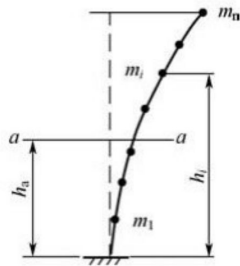

Figure 8.2.1 Diagram of earthquake action on vertical vessels supported by skirts

F_{bi} —horizontal earthquake action caused by the i^{th} -section concentrated mass(N);

h_i —distance between the i^{th} section concentrated mass and ground(mm);

h_a —distance between any calculated cross-section a-a and ground(mm).

8.2.2 If mode superposition response spectrum method is used, the bending moment on cross-section a-a caused by horizontal earthquake action (Figure 8.2.1) may be calculated according to the following formulas:

$$M_{Ea,j} = \sum_{i=k}^n F_{bij} (h_i - h_a) \quad (8.2.2-1)$$

$$M_{Ea} = \sqrt{\sum M_{Ea,j}^2} \quad (8.2.2-2)$$

Where:

$M_{Ea,j}$ —earthquake bending moment on any calculated cross-section a-a in the j^{th} -order vibration mode(N·mm);

F_{bij} —horizontal earthquake action in the j^{th} -order vibration mode caused by the i^{th} -section concentrated mass(N).

8.2.3 In the seismic checking of vertical vessels supported by skirts, the maximum bending moment applied on any cross-section a-a may be calculated according to following formulas:

$$M_{\max,a} = M_{Ea} + 0.25M_{Wa} + M_c \quad (8.2.3-1)$$

$$M_c = m_c g l_e \quad (8.2.3-2)$$

Where:

$M_{\max,a}$ —maximum bending moment(N·mm) on any calculated cross-section a-a;

M_{Wa} —wind bending moment on any calculated cross-section a-a (N·mm), which is calculated according to the requirements of the current standard NB/T 47041 *Vertical Vessels Supported by Skirt*;

M_c —bending moment caused by eccentric mass(N·mm);

m_c —eccentric mass(kg);

l_e —distance from centroid of eccentric mass to centerline of vessel(mm).

8.2.4 The shear stress at the lap welds between skirt and shell may be calculated according to following formulas:

$$\frac{M_{\max,w}}{Z_w} + \frac{m_w g + F_{Vw}}{A_w} \leq 0.8[\sigma] \quad (8.2.4-1)$$

$$Z_w = 0.55D_{ot}^2 \delta_{es} \quad (8.2.4-2)$$

$$A_w = 0.7\pi D_{ot} \delta_{es} \quad (8.2.4-3)$$

Where:

$M_{\max,w}$ —maximum bending moment at cross-section of skirt welds(N·mm);

Z_w —section modulus of lap welds(mm³);

m_w —operating mass of vertical vessel above cross-section of skirt welds(kg);

F_{Vw} —vertical earthquake action on cross-section of skirt welds(N);

A_w —cross-sectional area of lap welds(mm²);

$[\sigma]$ —materials allowable stress of welded joints for seismic appraisal(MPa);

D_{ot} —outside diameter of top cross-section of skirt shell(mm) ;

δ_{es} —effective thickness of skirt shell(mm).

8.2.5 The tensile stress of butt welds between skirt and shell may be calculated according to following formula:

$$\frac{4M_{\max,w}}{\pi D_{it}^2 \delta_{es}} - \frac{m_w g - F_{Vw}}{\pi D_{it} \delta_{es}} \leq 0.6[\sigma] \quad (8.2.5)$$

Where:

D_{it} —inside diameter of top cross-section of the skirt shell(mm).

8.2.6 The thread root diameter of anchor bolts may be calculated according to following formulas:

$$d_1 = \sqrt{\frac{4\sigma_B A_b}{\pi n [\sigma]_{bt}}} + C_2 \quad (8.2.6-1)$$

$$\sigma_B = \frac{M_{\max,0}}{Z_b} - \frac{m_0 g - F_{V0}}{A_b} \quad (8.2.6-2)$$

Where:

d_1 —thread root diameter of anchor bolt(mm) ;

σ_B —maximum tensile stress of anchor bolt(MPa) ;

A_b —area of base ring(mm²) ;

n —quantity of anchor bolts ;

$[\sigma]_{bt}$ —material allowable stress of anchor bolts(MPa) ;

C_2 —corrosion allowance(mm) ;

$M_{\max,0}$ —maximum bending moment on bottom cross-section 0-0 of skirt(N·mm) ;

Z_b —bending section modulus of base ring(mm³) ;

m_0 —operating mass of vessel(kg) ;

F_{V0} —vertical earthquake action at bottom cross-section of vessel(N).

8.2.7 The thickness of base ring without rib may be calculated according to following formulas:

$$\delta_b = 1.73b \sqrt{\sigma_{b\max} / [\sigma]_b} \quad (8.2.7-1)$$

$$\sigma_{b\max} = \frac{M_{\max,0}}{Z_b} + \frac{m_0 g + F_{V0}}{A_b} \quad (8.2.7-2)$$

Where:

δ_b —thickness of base ring(mm) ;

b —1/2 of the difference between outside diameter of base ring and inside diameter of skirt shell (mm) ;

$\sigma_{b\max}$ —maximum compressive stress at base ring(MPa) ;

$[\sigma]_b$ —allowable stress of material of base ring(MPa).

8.2.8 The thickness of base ring with ribs may be calculated according to following formulas:

$$\delta_b = \sqrt{6M_s / [\sigma]_b} \quad (8.2.8-1)$$

$$M_s = \max \{ |M_x|, |M_y| \} \quad (8.2.8-2)$$

$$M_x = C_x \sigma_{b\max} b^2 \quad (8.2.8-3)$$

$$M_y = C_y \sigma_{b\max} l^2 \quad (8.2.8-4)$$

Where:

M_s —calculated moment of rectangular plate(N·mm) ;

M_x —moment of rectangular plate with respect to x axis(N·mm) ;

M_y —moment of rectangular plate with respect to y axis(N·mm) ;

C_x —moment coefficient of rectangular plate with respect to x axis, which is taken according to Table 8.2.8;

C_y —moment coefficient of rectangular plate with respect to y axis, which is taken according to Table 8.2.8;

l —maximum distance between inner sides of two adjacent ribs(mm).

Table 8.2.8 Moment coefficients C_x and C_y of rectangular plate

b/l	C_x	C_y	b/l	C_x	C_y
0	-0.5000	0	1.6	-0.0485	0.1260
0.1	-0.5000	0.0000	1.7	-0.0430	0.1270
0.2	-0.4900	0.0006	1.8	-0.0384	0.1290
0.3	-0.4480	0.0051	1.9	-0.0345	0.1300
0.4	-0.3850	0.0151	2.0	-0.0312	0.1300
0.5	-0.3190	0.0293	2.1	-0.0283	0.1310
0.6	-0.2600	0.0453	2.2	-0.0258	0.1320
0.7	-0.2120	0.0610	2.3	-0.0236	0.1320
0.8	-0.1730	0.0751	2.4	-0.0217	0.1320
0.9	-0.1420	0.0872	2.5	-0.0200	0.1330
1.0	-0.1180	0.0972	2.6	-0.0185	0.1330
1.1	-0.0995	0.1050	2.7	-0.0171	0.1330
1.2	-0.0846	0.1120	2.8	-0.0159	0.1330
1.3	-0.0726	0.1160	2.9	-0.0149	0.1330
1.4	-0.0629	0.1200	3.0	-0.0139	0.1330
1.5	-0.0550	0.1230	-	-	-

8.2.9 The compressive stress of ribs may be calculated according to following formula:

$$\frac{\sigma_B A_{bt}}{m_1 \delta_G l_2} \leq [\sigma]_c \quad (8.2.9)$$

Where:

A_{bt} —cross-sectional area of an anchor bolt(mm^2);

n_1 —quantity of ribs corresponding to one anchor bolt;

δ_G —thickness of a rib(mm);

l_2 —width of a rib(mm);

$[\sigma]_c$ —critical allowable compressive stress of ribs(MPa).

8.2.10 The stress of partitioned cover plate without wear plate may be calculated according to the following formula:

$$\frac{\sigma_B A_{bt} l_3}{n(l_2 - d_3) \delta_c^2} \leq [\sigma]_z \quad (8.2.10)$$

Where:

l_3 —distance between inner sides of ribs(mm);

d_3 —diameter of anchor bolt hole in cover plate(mm);

δ_c —thickness of cover plate(mm);

$[\sigma]_z$ —material allowable stress of cover plate(MPa).

8.2.11 The stress of partitioned cover plate with wear plate may be calculated according to the

following formula:

$$\frac{\sigma_B A_{bt} l_3}{n[(l_2 - d_3)\delta_c^2 + (l_4 - d_2)\delta_z^2]} \leq [\sigma]_z \quad (8.2.11)$$

Where:

l_4 —width of wear plate(mm);

d_2 —diameter of anchor bolt hole in wear plate(mm);

δ_z —thickness of wear plate(mm).

8.2.12 The stress of ring cover plate without a wear plate may be calculated according to the following formula:

$$\frac{3\sigma_B A_{bt} l_3}{4n(l_2 - d_3)\delta_c^2} \leq [\sigma]_z \quad (8.2.12)$$

8.2.13 The stress of ring cover plate with a wear plate may be calculated according to following formula:

$$\frac{3\sigma_B A_{bt} l_3}{4n[(l_2 - d_3)\delta_c^2 + (l_4 - d_2)\delta_z^2]} \leq [\sigma]_z \quad (8.2.13)$$

8.3 Seismic measures

8.3.1 If the connection welds between the shell and the skirt can not meet the requirements, evenly distributed reinforcing ribs should be provided around the periphery of the connection for reinforcing purpose.

8.3.2 If the anchor bolts can not meet the requirements, additional anchor bolts should be provided at inside or outside the skirt for reinforcing purpose.

8.3.3 If the seismic checking shows that the base ring can not meet the requirements, the reinforced concrete foundation shall be enlarged or other measures shall be taken.

8.3.4 If the seismic checking shows that the ribs can not meet the requirements, additional ribs shall be provided or other measures shall be taken.

8.3.5 If the seismic checking shows that the cover plate can not meet the requirements, additional wear plate shall be provided or other measures shall be taken.

8.3.6 If the appearance of the connection welds between the skirt and the vessel or anchor bolts chair can not meet the requirements, repair welding shall be carried out and the welds shall be subjected to non-destructive test.

9 Spherical tanks supported by columns

9.1 General requirements

9.1.1 The seismic design of a spherical tank with adjustable or fixed type tie rods which is supported by columns along the equator plane (with the centerlines of the columns being tangent to or secant to the inner wall of the spherical shell) shall meet the requirements of this chapter.

9.1.2 The appearance of spherical tanks that require seismic appraisal shall meet the following requirements:

1 The connection welds between the spherical shell and column, column and lugs, tie rods and wing plates shall be equal strength joints as that of the corresponding thinner parts. The weld joints shall be fully filled, and shall be free of any surface defects;

2 The adjustable tie rods shall be properly tight and the tightness of the every tie rods shall be substantially the same. The tie rods shall not be welded together at their cross points;

3 The anchor bolts of the support columns shall not be deformed obviously;

4 The anchor bolts of the support columns shall be fastened with double nuts, or provided with anti-loosening devices.

9.1.3 The seismic appraisal and checking of spherical tanks shall involve:

1 Strength checking and stability checking for support columns;

2 Strength checking for anchor bolts;

3 Strength checking for base plate;

4 Strength checking for tie rods;

5 Strength checking for pins, gussets and wing plates;

6 Strength checking for connection welds between the gussets and support columns, tie rods and wing plates, and support columns and spherical shell.

9.1.4 The earthquake action on spherical tanks shall be calculated according to the requirements of the current national standard GB/T 50761 *Standard for Seismic Design of Petrochemical Steel Equipments*.

9.2 Earthquake effect and seismic checking

9.2.1 The gravity load applied on each support column of the spherical tank may be calculated according to the following formula:

$$G_{eq} = \frac{m_{eq}g}{n} \quad (9.2.1)$$

Where:

G_{eq} —gravity load applied on each support column when spherical tank is under operating condition (N);

m_{eq} —equivalent mass of spherical tank under operating condition (kg), which is calculated according to the relevant requirements of the current national standard GB/T 50761 *Standard for Seismic Design of Petrochemical Steel Equipments*;

n —quantity of support columns.

9.2.2 The maximum bending moment caused by horizontal earthquake action and horizontal wind force may be calculated according to the following formulas:

$$M_{\max} = F_{\max} L \quad (9.2.2-1)$$

$$F_{\max} = F_e + 0.25F_w \quad (9.2.2-2)$$

Where:

M_{\max} —maximum bending moment caused by horizontal earthquake action and horizontal wind force (N·mm);

F_{\max} —maximum horizontal force(N);

L —distance from the equatorial plane of the spherical shell to the center of pin at the upper gusset (mm);

F_e —design value of horizontal earthquake action of spherical tank, which is calculated according to the relevant requirements of the current national standard GB/T 50761 *Standard for Seismic Design of Petrochemical Steel Equipments*(N);

F_w —horizontal wind force of spherical tank, which may be calculated according to the relevant requirements of the current national standard GB 12337 *Steel Spherical Tanks*(N).

9.2.3 The vertical load applied on support columns caused by the maximum bending moment may be calculated according to the following formula:

$$F_i = -\frac{2M_{\max} \cos\theta_i}{nR} \quad (9.2.3)$$

Where:

F_i —vertical load applied on the i^{th} support column caused by the maximum bending moment(N);

θ_i —azimuth angle of the support column($^{\circ}$), which is calculated according to Article 9.2.4;

R —radius of center circle of support columns(mm).

9.2.4 The azimuth angle of the i^{th} support column shall be determined according to the following requirements:

1 When the force is applied from direction A, the azimuth angle of the support columns may be calculated according to following formula:

$$\theta_i = i \frac{360^{\circ}}{n} \quad (9.2.4-1)$$

2 When the force is applied from direction B, the azimuth angle of the support columns may be calculated according to following formula:

$$\theta_i = \left(i - \frac{1}{2}\right) \frac{360^{\circ}}{n} \quad (9.2.4-2)$$

Where:

i —serial number of support columns within the range of 0° to 180° , as shown in Figure 9.2.4 and Figure 9.2.6-2.

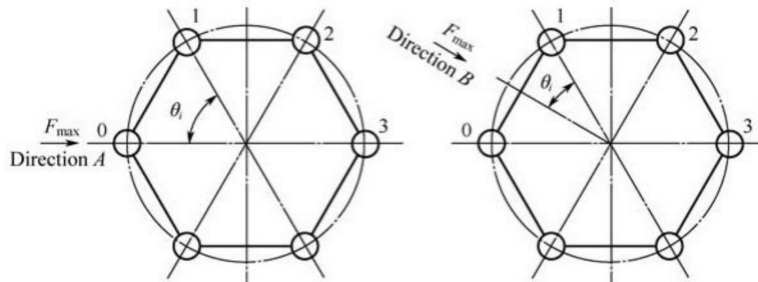

Figure 9.2.4 Serial number and azimuth angle of support columns

9.2.5 The vertical load applied by tie rods on a support column shall be determined according to the following requirements:

1 When any two neighboring support columns are connected with a tie rod, the vertical load applied by the tie rod on the support column may be calculated according to following formula:

$$P_{i-j} = \frac{lF_{\max} \sin \theta_j}{nR \sin \frac{180^\circ}{n}} \quad (9.2.5-1)$$

2 When a tie rod is connected between alternate support columns, the vertical load applied by the tie rod on the support column may be calculated according to following formula:

$$P_{i-j} = \frac{lF_{\max} \sin \theta_j}{nR \sin \frac{360^\circ}{n}} \quad (9.2.5-2)$$

Where:

- P_{i-j} —vertical load applied by the j^{th} tie rod on the i^{th} support column($i=j+1, j=0, 1, 2, 3, \dots$)(N);
- l —distance from the bottom surface of the base plate of the support column to the center of pin at the upper gusset(mm);
- θ_j —azimuth angle of the j^{th} tie rod($^\circ$), which may be calculated according to Article 9.2.6 of this standard.

9.2.6 The azimuth angle of the j^{th} tie rod shall be determined according to the following requirements:

- 1 When any two adjacent support columns are connected with a tie rod(Figure 9.2.6-1):
 - 1)When the force is applied from direction A, the azimuth angle of the tie rod may be calculated using the following formula:

$$\theta_j = \left(j + \frac{1}{2}\right) \frac{360^\circ}{n} \quad (9.2.6-1)$$

- 2)When the force is applied from direction B, the azimuth angle of the tie rod may be calculated using the following formula:

$$\theta_j = j \frac{360^\circ}{n} \quad (9.2.6-2)$$

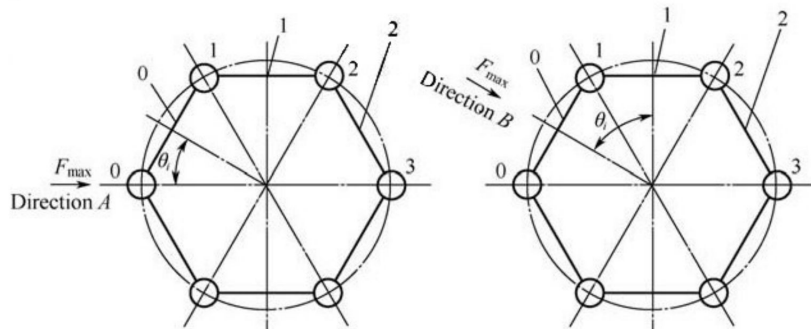

Figure 9.2.6-1 Serial number and azimuth angle of tie rods

- 2 When a tie rod is connected between alternate support columns(Figure 9.2.6-2):
 - 1)When the force is applied from direction A, the azimuth angle of the tie rod may be calculated using the Formula(9.2.6-2);
 - 2)When the force is applied from direction B, the azimuth angle of the tie rod may be calculated according to following formula:

$$\theta_j = \left(j - \frac{1}{2}\right) \frac{360^\circ}{n} \quad (9.2.6-3)$$

Where:

- j —serial number of tie rods within 0° to 180° , as shown in Figure 9.2.6-1 and Figure 9.2.6-2.

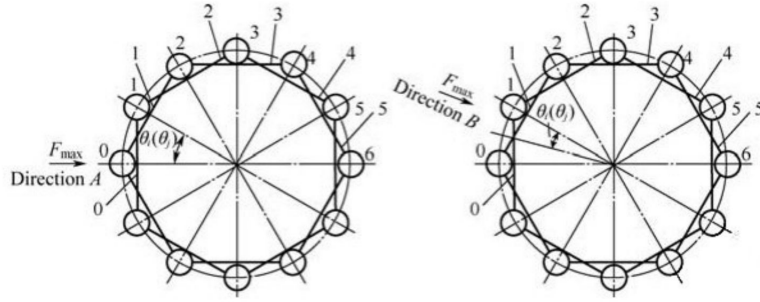

Figure 9.2.6-2 Serial number and azimuth angle of tie rods

9.2.7 The maximum vertical loads on a support column may be calculated according to following formula:

$$W_{eq} = G_{eq} + (F_i + P_{i-j})_{max} \quad (9.2.7)$$

Where:

W_{eq} —maximum vertical load on a support column when the spherical tank is under operating condition(N);

$(F_i + P_{i-j})_{max}$ —maximum value of $(F_i + P_{i-j})$ of every support column(N), which is determined according to Article 9.2.8.

9.2.8 When the force is applied from direction A or B, the maximum value of vertical load $(F_i)_{max}$ caused by the maximum bending moment on a support column, the maximum value of vertical load $(P_{i-j})_{max}$ applied by a tie rod on the support column, and the maximum value of the sum of the both may be determined according to Table 9.2.8.

Table 9.2.8 Calculation of $(F_i)_{max}$, $(P_{i-j})_{max}$ and $(F_i + P_{i-j})_{max}$

Connection type of tie rods	Quantity of support columns(pcs)	$(F_i)_{max}$ (N)	$(P_{i-j})_{max}$ (N)	$(F_i + P_{i-j})_{max}$ (N)
Tie rods connecting every adjacent support columns	4	0.5000a	0.5000b	0.5000a+0.5000b, direction A, 2 nd support column
	5	0.3236a	0.3236b	0.3236a+0.3236b, direction A, 2 nd support column
	6	0.3333a	0.3333b	0.3333a+0.3333b, direction A, 3 rd support column
	8	0.2500a	0.3266b	0.1768a+0.3018b, direction A, 3 rd support column
	10	0.2000a	0.3236b	0.1176a+0.3078b, direction B, 4 th support column
	12	0.1667a	0.3220b	0.0833a+0.3110b, direction B, 4 th support column
	14	0.1429a	0.3210b	0.0620a+0.3129b, direction B, 5 th support column
	16	0.1250a	0.3204b	0.0478a+0.3142b, direction A, 5 th support column
	18	0.1111a	0.3199b	0.0380a+0.3151b, direction B, 6 th support column
	20	0.1000a	0.3196b	0.0309a+0.3157b, direction A, 6 th support column
Tie rods connecting alternate support columns	8	0.2500a	0.2500b	0.2500a+0.2500b, direction A, 4 th support column
	10	0.2000a	0.2000b	0.2000a+0.2000b, direction A, 5 th support column
	12	0.1667a	0.1667b	0.1667a+0.1667b, direction A, 6 th support column
	14	0.1429a	0.1646b	0.1429a+0.1429b, direction A, 7 th support column
	16	0.1250a	0.1633b	0.0694a+0.1602b, direction B, 6 th support column
	18	0.1111a	0.1624b	0.1094a+0.1624b, direction B, 9 th support column
	20	0.1000a	0.1618b	0.0988a+0.1469b, direction B, 10 th support column

Note: $a=M_{max}/R, b=F_{max} /R$.

9.2.9 The membrane stress along equator line of the spherical shell under operating condition may be calculated according to following formula:

$$\sigma_{oc} = \frac{(p + p_{oc})(D_i + \delta_c)}{4\delta_c} \quad (9.2.9)$$

Where:

- σ_{oc} —membrane stress along equator line of the spherical shell under operating condition(MPa);
- p —design pressure(MPa);
- p_{oc} —liquid hydrostatic pressure of medium along equator line under operating condition(MPa);
- D_i —inside diameter of spherical shell(mm);
- δ_e —effective thickness of spherical shell(mm).

9.2.10 The eccentric bending moment on support columns under operating condition may be calculated according to following formula:

$$M_{o1} = \frac{\sigma_{oc} R_i W_{eq}}{E} (1 - \mu) \quad (9.2.10)$$

Where:

- M_{o1} —eccentric bending moment on support column under operating condition(N·mm);
- R_i —inside radius of spherical shell(mm);
- μ —poisson's ratio of the material of spherical shell, which is taken as $\mu=0.3$;
- E —material elasticity modulus of the spherical shell under room temperature(MPa).

9.2.11 The additional bending moment on a support column under operating condition may be calculated according to following formula:

$$M_{o2} = \frac{6E_s I \sigma_{oc} R_i}{H_0^2 E} (1 - \mu) \quad (9.2.11)$$

Where:

- M_{o2} —additional bending moment on a support column under operating condition(N·mm);
- E_s —material elasticity modulus of the support column under room temperature(MPa);
- I —moment of inertia of cross-section of the support column(mm⁴);
- H_0 —distance between the spherical shell center and the bottom surface of base plate of the support column(mm).

9.2.12 The total bending moment on a support column under operating condition may be calculated according to following formula:

$$M_o = M_{o1} + M_{o2} \quad (9.2.12)$$

Where:

- M_o —total bending moment on a support column under operating condition(N·mm).

9.2.13 The stability of a support column under operating condition may be determined according to following formulas:

$$\frac{W_{eq}}{\phi_p A} + \frac{\beta_m M_o}{\gamma Z \left(1 - 0.8 \frac{W_{eq}}{W_{EX}}\right)} \leq 0.9 R_{eL} \quad (9.2.13-1)$$

$$Z = \frac{\pi (d_o^4 - d_i^4)}{32 d_o} \quad (9.2.13-2)$$

$$W_{EX} = \frac{\pi^2 E_s A}{\lambda^2} \quad (9.2.13-3)$$

$$\lambda = \frac{k_3 H_0}{r_i} \quad (9.2.13-4)$$

$$r_i = \sqrt{\frac{I}{A}} \quad (9.2.13-5)$$

Where:

- ϕ_p —stability coefficient of the support column under axial compression in the application plane of bending moment, which is calculated according to Article 9.2.14;

A —cross-sectional area of single support column(mm^2);

β_m —equivalent bending moment coefficient, which is taken as 1.0;

γ —plastic adaption coefficient of cross-section, which is taken as 1.15;

Z —section coefficient of single support column(mm^3);

W_{EX} —euler's critical force(N);

R_{el} —yield strength or 0.2% offset yield strength stipulated in the standard of support column material under room temperature(MPa);

d_o —outside diameter of support column(mm);

d_i —inside diameter of support column(mm);

λ —slenderness ratio of support column;

k_3 —calculation length coefficient, which is taken as 1.0;

r_i —radius of inertia of support column(mm).

9.2.14 The stability coefficient of the support column under axial compression in the application plane of bending moment shall be determined according to the following requirements:

1 It shall be selected from Tables 9.2.14-1 to 9.2.14-3 or Table 9.2.14-4, according to the slenderness ratio and type of column and material of column.

Table 9.2.14-1 Stability coefficient ϕ_p of Q235A wrought-steel pipe support columns under axial compression

λ	0	1	2	3	4	5	6	7	8	9
0	1.000	1.000	1.000	1.000	0.999	0.999	0.998	0.998	0.997	0.996
10	0.995	0.994	0.993	0.992	0.991	0.989	0.988	0.986	0.985	0.983
20	0.981	0.979	0.977	0.976	0.974	0.972	0.970	0.968	0.966	0.964
30	0.963	0.961	0.959	0.957	0.955	0.952	0.950	0.948	0.946	0.944
40	0.941	0.939	0.937	0.934	0.932	0.929	0.927	0.924	0.921	0.919
50	0.916	0.913	0.910	0.907	0.904	0.900	0.897	0.894	0.890	0.886
60	0.883	0.879	0.875	0.871	0.867	0.863	0.858	0.854	0.849	0.844
70	0.839	0.834	0.829	0.824	0.818	0.813	0.807	0.801	0.795	0.789
80	0.783	0.776	0.770	0.763	0.757	0.750	0.743	0.736	0.728	0.721
90	0.714	0.706	0.699	0.691	0.684	0.676	0.668	0.661	0.653	0.645
100	0.638	0.630	0.622	0.615	0.607	0.600	0.592	0.585	0.577	0.570

Note: The intermediate values are calculated by linear interpolation method.

Table 9.2.14-2 Stability coefficient ϕ_p of Q235A welded-steel pipe support columns under axial compression

λ	0	1	2	3	4	5	6	7	8	9
0	1.000	1.000	1.000	0.999	0.999	0.998	0.997	0.996	0.995	0.994
10	0.992	0.991	0.989	0.987	0.985	0.983	0.981	0.978	0.976	0.973
20	0.970	0.967	0.963	0.960	0.957	0.953	0.950	0.946	0.943	0.939
30	0.936	0.932	0.929	0.925	0.922	0.918	0.914	0.910	0.906	0.903
40	0.899	0.895	0.891	0.887	0.882	0.878	0.874	0.870	0.865	0.861
50	0.856	0.852	0.847	0.842	0.838	0.833	0.828	0.823	0.818	0.813
60	0.807	0.802	0.797	0.791	0.786	0.780	0.774	0.769	0.763	0.757
70	0.751	0.745	0.739	0.732	0.726	0.720	0.714	0.707	0.701	0.694
80	0.688	0.681	0.675	0.668	0.661	0.655	0.648	0.641	0.635	0.628
90	0.621	0.614	0.608	0.601	0.594	0.588	0.581	0.575	0.568	0.561
100	0.555	0.549	0.542	0.536	0.529	0.523	0.517	0.511	0.505	0.499

Note: The intermediate values are calculated by linear interpolation method.

Table 9.2.14-3 Stability coefficient ϕ_p of Q345A wrought-steel pipe support columns under axial compression

λ	0	1	2	3	4	5	6	7	8	9
0	1.000	1.000	1.000	0.999	0.999	0.998	0.997	0.997	0.996	0.994
10	0.993	0.992	0.990	0.988	0.986	0.984	0.982	0.980	0.978	0.975
20	0.973	0.971	0.969	0.967	0.964	0.962	0.960	0.957	0.955	0.952
30	0.950	0.947	0.944	0.941	0.939	0.936	0.933	0.930	0.927	0.923
40	0.920	0.917	0.913	0.909	0.906	0.902	0.898	0.894	0.889	0.885
50	0.881	0.876	0.871	0.866	0.861	0.855	0.850	0.844	0.838	0.832
60	0.825	0.819	0.812	0.805	0.798	0.791	0.783	0.775	0.767	0.759
70	0.751	0.742	0.734	0.725	0.716	0.707	0.698	0.689	0.680	0.671
80	0.661	0.652	0.643	0.633	0.624	0.615	0.606	0.596	0.587	0.578
90	0.570	0.561	0.552	0.543	0.535	0.527	0.518	0.510	0.502	0.494
100	0.487	0.479	0.471	0.464	0.457	0.450	0.443	0.436	0.429	0.423

Note: The intermediate values are calculated by linear interpolation method.

Table 9.2.14-4 Stability coefficient ϕ_p of Q345A welded-steel pipe support columns under axial compression

λ	0	1	2	3	4	5	6	7	8	9
0	1.000	1.000	1.000	0.999	0.998	0.997	0.996	0.995	0.993	0.991
10	0.989	0.987	0.984	0.981	0.978	0.975	0.972	0.968	0.964	0.960
20	0.956	0.952	0.948	0.943	0.939	0.935	0.931	0.926	0.922	0.917
30	0.913	0.908	0.903	0.899	0.894	0.889	0.884	0.879	0.874	0.869
40	0.863	0.858	0.852	0.847	0.841	0.835	0.829	0.823	0.817	0.811
50	0.804	0.798	0.791	0.784	0.778	0.771	0.764	0.756	0.749	0.742
60	0.734	0.727	0.719	0.711	0.704	0.696	0.688	0.680	0.672	0.664
70	0.656	0.648	0.640	0.632	0.623	0.615	0.607	0.599	0.591	0.583
80	0.575	0.567	0.559	0.551	0.544	0.536	0.528	0.521	0.513	0.506
90	0.499	0.491	0.484	0.477	0.470	0.463	0.457	0.450	0.443	0.437
100	0.431	0.424	0.418	0.412	0.406	0.400	0.395	0.389	0.384	0.378

Note: The intermediate values are calculated by linear interpolation method.

2 For materials not listed in Tables 9.2.14-1 to 9.2.14-4, the ϕ_p may be determined according to the following requirements:

1) In case of $\lambda \leq 0.215$, ϕ_p may be calculated according to the following formula:

$$\phi_p = 1 - a_1 \bar{\lambda}^2 \quad (9.2.14-1)$$

2) In case of $\lambda > 0.215$, ϕ_p may be calculated according to following formulas:

$$\phi_p = \frac{1}{2\bar{\lambda}^2} \left[(a_2 + a_3 \bar{\lambda} + \bar{\lambda}^2) - \sqrt{(a_2 + a_3 \bar{\lambda} + \bar{\lambda}^2)^2 - 4\bar{\lambda}^2} \right] \quad (9.2.14-2)$$

$$\bar{\lambda} = \frac{\lambda}{\pi} \sqrt{\frac{R_{el}}{E_s}} \quad (9.2.14-3)$$

Where:

$\bar{\lambda}$ —converted slenderness ratio;

a_1, a_2, a_3 —coefficient, in the case of wrought-steel pipe, $a_1=0.41, a_2=0.986, a_3=0.152$; in the case of welded-steel pipe, $a_1=0.65, a_2=0.965, a_3=0.300$.

9.2.15 The shear stress of anchor bolts may be calculated according to the following requirements:

1 The horizontal force applied by the tie rod on the support column may be calculated according to following formula:

$$F_c = (P_{t-j})_{\max} \tan \beta \quad (9.2.15-1)$$

2 The frictional force between the base plate of support column and the foundation may be

calculated according to following formula:

$$F_s = f_s \cdot \frac{m_{\min} g}{n} \quad (9.2.15-2)$$

3 The shear stress may be calculated according to following formula:

$$\frac{4(F_c - F_s)}{\pi n_d d_B^2} \leq 0.58 R_{el} \quad (9.2.15-3)$$

Where:

F_c —horizontal force applied by the tie rod on the support column(N);

β —angle between tie rod and support column($^\circ$);

F_s —frictional force between the base plate of support column and the foundation(N);

f_s —frictional coefficient between the base plate of support column and the foundation, which is taken as 0.4 for steel vs.concrete and 0.3 for steel vs.steel;

m_{\min} —minimum mass of spherical tank(kg), which may be calculated according to the requirements of current national standard GB 12337 *Steel Spherical Tanks*;

n_d —quantity of anchor bolts for each support column;

d_B —thread root diameter of anchor bolts(mm);

R_{el} —yield strength or 0.2% offset yield strength stipulated in the standard of anchor bolts material under room temperature(MPa).

9.2.16 The bending stress of the base plate (Figure 9.2.16) may be calculated according to the following formula:

$$\frac{12W_{c1} l_b^2}{\pi D_b^2 \delta_b^2} \leq 0.9 R_{el} \quad (9.2.16)$$

Where:

l_b —distance from outer edge of the base plate to outer surface of the support column(mm);

D_b —diameter of base plate of support column(mm);

δ_b —thickness of base plate(mm);

R_{el} —yield strength or 0.2% offset yield strength stipulated in the standard of base plate material under room temperature (MPa).

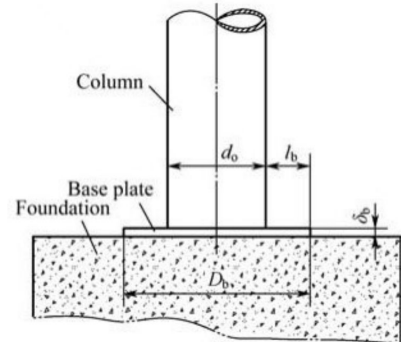

Figure 9.2.16 Base plate

9.2.17 The strength of the tie rod may be calculated according to the following formulas:

$$F_T = \frac{(P_{i-j})_{\max}}{\cos\beta} \quad (9.2.17-1)$$

$$\frac{4F_T}{\pi d_T^2} \leq 0.9 R_{el} \quad (9.2.17-2)$$

Where:

F_T —maximum tensile force of the tie rod(N);

d_T —thread root diameter of the tie rod(mm);

R_{el} —yield strength or 0.2% offset yield strength stipulated in the standard of tie rod material under room temperature(MPa).

9.2.18 The strength of connecting parts of a tie rod(Figure 9.2.18) may be calculated according to the following requirements:

1 The shear stress in pins may be calculated according to the following formula:

$$\frac{2F_T}{\pi d_p^2} \leq 0.58 R_{el} \quad (9.2.18-1)$$

Where:

d_p —diameter of pins(mm);

R_{el} —yield strength or 0.2% offset yield strength stipulated in the standard of pin material under room temperature(MPa).

2 The compressive stress in gusset and wing plate may be calculated according to the following formulas:

$$\frac{F_T}{d_p \delta_c} \leq R_{el} \quad (9.2.18-2)$$

$$\frac{F_T}{2d_p \delta_a} \leq R'_{el} \quad (9.2.18-3)$$

Where:

δ_c —thickness of gusset(mm);

R_{el} —yield strength or 0.2% offset yield strength stipulated in the standard of gusset material(MPa);

δ_a —thickness of wing plate(mm);

R'_{el} —yield strength or 0.2% offset yield strength stipulated in the standard of wing plate material (MPa).

3 The shear stress in welds (Figure 9.2.18) may be calculated according to the following requirements:

1)The shear stress in weld A between the gusset and the support column may be calculated according to following formula:

$$\frac{F_T}{1.41L_1S_1} \leq 0.58R_{el}\phi_a \quad (9.2.18-4)$$

2)The shear stress in weld B between the tie rod and the wing plate may be calculated according to following formula:

$$\frac{F_T}{2.82L_2S_2} \leq 0.58R'_{el}\phi_a \quad (9.2.18-5)$$

Where:

L_1 —single-side length of weld A(mm);

S_1 —fillet size at weld A(mm);

R_{el} —yield strength or 0.2% offset yield strength stipulated in the standard of support column or gusset material, whichever is less(MPa);

ϕ_p —fillet weld coefficient, which is taken as 0.6;

L_2 —single-side length of weld B(mm);

S_2 —fillet size at weld B(mm);

R'_{el} —yield strength or 0.2% offset yield strength stipulated in the standard of tie rod or wing plate material, whichever is less(MPa).

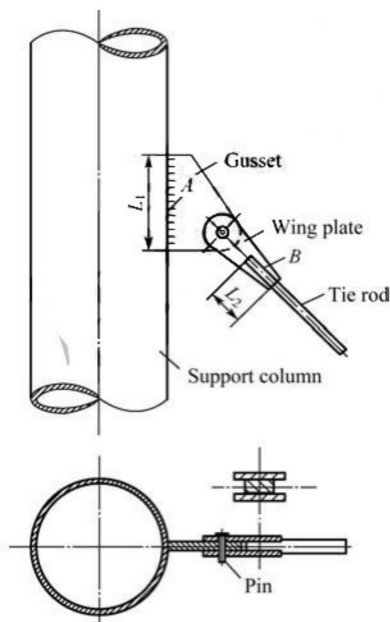

Figure 9.2.18 Connecting parts between tie rod and support column

9.2.19 The shear stress in connection welds between support columns and spherical shell (Figure 9.2.19) may be calculated according to following formulas:

$$\frac{W}{1.41L_w S} \leq 0.58R_{el}\phi_a \quad (9.2.19-1)$$

$$W = G_{eq} + (F_i)_{max} \quad (9.2.19-2)$$

$$L_w \approx \sqrt{\left(\frac{d_o}{2}\right)^2 + L_a^2} \quad (9.2.19-3)$$

Where:

- W —maximum vertical load applied on connection welds between support column and spherical shell(N);
- L_w —single-side arc length of connection welds between support column and spherical shell(mm);
- S —fillet size of connection welds between support column and spherical shell(mm);
- R_{el} —yield strength or 0.2% offset yield strength stipulated in the standard of support column or spherical shell material, whichever is less(MPa);
- $(F_i)_{max}$ —maximum vertical load caused by maximum bending moment on support column(N), which is consulted from Table 9.2.8;
- L_a —vertical distance from the top surface of support column to the lowest point where the support column connects with the spherical shell(mm).

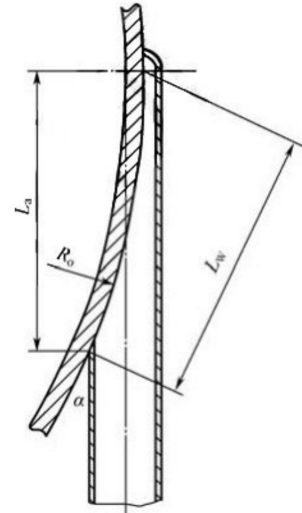

Figure 9.2.19 Connecting weld between support column and spherical shell

9.3 Seismic measures

9.3.1 If the seismic checking shows that the stability of support columns can not meet the requirements, profile steels shall be welded to the support columns to improve their stability.

9.3.2 In the case of structures with tie rods, if tie rods can not meet the requirements of seismic checking, the tie rods shall be reinforced by increasing their diameter or being replaced with higher strength materials, or by increasing the quantity of the tie rods.

9.3.3 If anchor bolts can not meet the requirements of seismic checking, they shall be reinforced as follows:

1 \ If additional expansion bolts are used, they may be directly inserted from the base plate of the support column into the foundation. The diameter of the bolts should not be less than M16 and the burial depth into the foundation should not be less than 120mm;

2 \ If extra structural reinforcing parts are welded on the support columns and base plate, expansion bolts shall be used to fix them to the foundation.

9.3.4 The support columns, tie rods and anchor bolts shall be reinforced by following principle of making appropriate allowance and avoiding excessive reinforcing.

9.3.5 If the seismic checking shows that the strength of base plate can not meet the requirements, profiles steel shall be welded to the base plate to improve its bending capability.

9.3.6 If pins, gusset and wing plate can not meet the requirements, they shall be reinforced by increasing the diameter of the pins and the thickness of the gusset and wing plate, or being replaced with higher strength materials.

9.3.7 If the connection welds between gusset and support column, tie rods and wing plate, support columns and spherical shell can not meet the strength requirement, repair weld shall be made to the requirement of fillet size, and the surface of the welds shall be subject to non-destructive test.

10 Vertical cylindrical storage tanks

10.1 General requirements

10.1.1 The seismic appraisal of flat-bottomed welded vertical cylindrical storage tanks at atmospheric pressure which have a height/diameter ratio not greater than 1.6 and a nominal capacity greater than or equal to 100m³(referred to as "tank") shall meet the requirements of this chapter.

10.1.2 The space between the upper surface of the liquid in the tank and the top cover shall not be less than 4% of the capacity of the tank.

10.1.3 Where the seismic precautionary intensity is lower than 7 degree, the seismic checking may be exempted, but its appearance shall meet the requirement of Article 10.1.4.

10.1.4 The appearance of tank that require seismic appraisal shall meet the following requirements:

1 The welds of the tank shell, fillet welds between tank shell and tank bottom plate, welds between bottom plates, roof plates and rim plates of pontoon as well as welds at other important points shall be intact and free of any leakage and cracks;

2 The sealing between floating roof and tank shell shall be intact, the connecting parts between guiding device and rotating stairs shall be reliably installed and contact with each other properly, and the connection between ladders and tank shell shall be intact;

3 The various attachments, including the breather valve, flame arrester, transparent hole cover and gauging hatch cover at floating roof of the tank shall be connected reliably;

4 The tank shall be provided with well-functioning electrical grounding device. Good conductivity between the floating roof, rotating stair and tank shell shall be ensured;

5 Reasonable gap shall be ensured between the guide tube and the floating roof.

10.1.5 Where the seismic precautionary intensity is 8 degree and above, flexible connection should be made between large-diameter rigid piping and the tank.

10.2 Earthquake effect and seismic checking

10.2.1 The basic natural vibration period of liquid-tank coupling vibration shall be calculated according to the requirements of the current national standard GB/T 50761 *Standard for Seismic Design of Petrochemical Steel Equipments*. The measured thickness of the walls at 1/3 tank height shall be determined according to Article 4.0.3 of this standard.

10.2.2 The basic natural vibration period of stored liquid sloshing, horizontal earthquake action, and overturning moment on the bottom surface of the tank due to the horizontal earthquake action shall be calculated according to the requirements of the current national standard GB/T 50761 *Standard for Seismic Design of Petrochemical Steel Equipments*.

10.2.3 The critical stress of vertical stability of the first shell course shall be calculated according to the requirements of the current national standard GB/T 50761 *Standard for Seismic Design of Petrochemical Steel Equipments*, and the measured effective thickness of the first shell course shall be determined according to Article 4.0.3 of this standard.

10.2.4 The allowable critical stress of stability of the first shell course shall be calculated according to

following formula:

$$[\sigma]_{cr} = \frac{\sigma_{cr}}{1.3} \quad (10.2.4)$$

Where:

$[\sigma]_{cr}$ —allowable critical stress of vertical stability of the first shell course(MPa);

σ_{cr} —critical stress of vertical stability of the first shell course(MPa).

10.2.5 The uplift force and resistance force per unit length along perimeter of the tank bottom, vertical compressive stress at bottom of anchored tank, tensile stress of anchor bolts, and vertical compressive stress at bottom of tank shell of unanchored tank shall be calculated according to the requirements of the current national standard GB/T 50761 *Standard for Seismic Design of Petrochemical Steel Equipments*.

10.2.6 The throat size of fillet welds between the tank shell and annular bottom plate shall be calculated according to the following formula:

$$h_f \geq C_f \delta_1 \quad (10.2.6)$$

Where:

h_f —throat size of fillet welds between the tank shell and annular bottom plate(mm);

C_f —a coefficient, which is taken as 0.322 for Q235 type and Q345R steel tanks whose design temperature is atmospheric temperature;

δ_1 —effective thickness of the first shell course(mm).

10.2.7 The sloshing height of stored liquid shall be calculated according to the requirements of the current national standard GB/T 50761 *Standard for Seismic Design of Petrochemical Steel Equipments*.

10.2.8 The guide tube of the floating roof and opening in the steel cover plate of the guide tube shall ensure sufficient gap. The minimum gap between the guide tube of the floating roof and the opening in the steel cover plate for the guide tube may be calculated according to following formula:

$$\Delta F \geq (\sqrt{R^2 + h_v^2} - R) \times 2 \quad (10.2.8)$$

Where:

ΔF —gap between the guide tube and opening in the steel cover plate(m);

R —inside radius of tank(m);

h_v —sloshing height of stored liquid(m).

10.2.9 In the case of tanks containing flammable or toxic liquid, for floating roof tank and dome roof tank, the distance from the liquid level to the top of the tank shell shall be greater than the sloshing height; for the internal floating roof tank, the distance from the liquid level to the lower edge of the overflow drain on the tank shell shall be greater than the sloshing height.

10.3 Seismic measures

10.3.1 If the checking shows that the first shell course can not meet the requirements, additional reinforcement pads shall be provided. Specifically, the reinforcement pads may be directly welded to or bolted to the first shell course.

10.3.2 If the checking shows that a tank's capability against overturning can not meet the requirements, the tank shall be fixed to the foundation with anchor bolts.

10.3.3 For the tank whose walls are difficult to reinforce, and the tank where the sloshing height exceeds the distance from the liquid level to the top of the tank shell or the distance from the liquid level to the lower edge of the overflow drain on the tank shell, the liquid level may be reduced according to the results of seismic checking.

11 Heaters

11.1 General requirements

11.1.1 Except for ethylene crackers, the seismic appraisal of heater, combustion heater, auxiliary combustion chamber, sulfur burning heater, sulfur tail gas incinerator, etc., as well as combined smoke & air ducts and stack of waste heat recovery system mounted on ground (hereinafter collectively referred to as "heater") shall meet the requirements of this chapter.

11.1.2 The structural system of heaters that require seismic appraisal shall meet the following requirements:

- 1 There shall be reasonable transmission route of earthquake action;
- 2 Provision shall be made to prevent loss of seismic capability or gravity load bearing capability of the entire structure as a result of partial damage of structure or members;
- 3 Necessary seismic resistance capability, good deformation capability and seismic energy dissipation capability shall be provided;
- 4 Measures shall be taken for the possible weak points to increase their seismic capability;
- 5 Several seismic precautionary lines should be provided for large-sized heaters;
- 6 Reasonable distribution of stiffness and bearing capacity should be ensured to prevent excessive stress concentration or plastic deformation concentration due to weak points resulting from local weakening or abrupt change;
- 7 The joint of members shall not be damaged prior to the damage of their members;
- 8 Significantly irregular structural configuration shall not be used for heaters.

11.1.3 The seismic precautionary category of heaters shall be category B stipulated in the current national standard GB 50453 *Standard for Classification of Seismic Protection of Buildings and Special Structures in Petrochemical Engineering*.

11.2 Earthquake effect and seismic checking

11.2.1 The earthquake action on the heater structures shall comply with the following requirements:

1 For the framework structures of box heater and convection section of cylindrical heater, the horizontal earthquake action shall be calculated in two principal direction on the horizontal plane, and seismic checking shall be carried out. The horizontal earthquake action in each direction shall be resisted by the lateral force resisting members in that direction;

2 In the case of a structure on which the distribution of mass and stiffness are apparently asymmetrical, the torsional effect on the structure due to two-way horizontal earthquake action shall be taken into account. In other cases, the torsional effect shall be taken into account by adjusting the earthquake action effect;

3 In the case of long-span structures and long-cantilever structures of heaters in regions where the basic acceleration of ground motion is greater than or equal to 0.20g, or the seismic precautionary intensity is 8 degree and above, and vertical structure of heaters in regions where the basic acceleration of ground motion is 0.40g, or the seismic precautionary intensity is 9 degree, the vertical earthquake

action shall be calculated;

4 For horizontal heater, it is allowed to calculate only the lateral horizontal earthquake action on the heater body, and seismic checking shall be carried out.

11.2.2 The seismic checking of heater structures shall be carried out according to following methods:

1 For vertical(box-type) heaters with a height of not greater than 40m (including the height of stack at the top of the heaters), base shear force method may be used.

2 For tubular heaters except for those described in sub-clause 1) of this clause, mode-superposition response spectrum method shall be used.

3 For horizontal heaters, base shear force method shall be used. The earthquake influence coefficient may take the maximum value.

4 For stack mounted on ground with a height not greater than 40 m, base shear force method may be used; if it is higher than 40 m, mode-superposition response spectrum method shall be used.

5 The earthquake action on the auxiliary equipment of heaters and waste heat recovery system mounted on ground may be calculated according to following methods:

1) For air preheater steel frames mounted on ground, base shear force method may be used;

2) For overhead flues and their supports, if the horizontal earthquake action normal to the direction of length of flues is calculated only, the design response-spectra method applicable to ground equipment may be used, the seismic influence coefficient may take the maximum value.

11.2.3 In calculation of earthquake action, the representative gravity load of heaters shall be taken as the sum of standard value of weight of the structure and accessories and the combination value of the different variable loads. The combination coefficient of live loads on the platform shall be taken as 0.5.

11.2.4 Where the horizontal earthquake action on the stack at the top of vertical(box-type) heaters is calculated by base shear force method, the earthquake action on the stack shall be multiplied by an amplification coefficient of 2.0, and the increased earthquake action effect may be applied to calculate the wall thickness of the stack and its connecting parts only. In calculation of earthquake action on the heater body structure, the mass of stack on the top of the heaters may be regarded as a concentrated mass.

11.2.5 When the torsional effect due to horizontal earthquake action on the steel structure of heaters is calculated, the earthquake action effect on two side frameworks parallel to the direction of earthquake action shall be multiplied by an amplification coefficient which is taken as 1.15 for short side and 1.05 for long side. If the torsional stiffness is small, this amplification coefficient may be taken as 1.3.

11.2.6 The seismic checking of the structures of heaters shall meet the following requirements:

1 If the design basic acceleration of ground motion is 0.05g or the seismic precautionary intensity is 6 degree, seismic checking of the cross-sections may be exempted; however the relevant seismic measures shall be taken;

2 If the design basic acceleration of ground motion is 0.10g and above or the seismic precautionary intensity is 7 degree and above, seismic checking of the cross-sections under the action of frequent earthquakes shall be carried out;

3 If the design basic acceleration of ground motion is 0.10g and above or the seismic precautionary intensity is 7 degree and above, relevant deformation checking shall be carried out.

11.2.7 The earthquake action on the heaters and the seismic checking of the structures shall be carried

out according to the requirements of current national standard GB 50011 *Code for Seismic Design of Buildings*.

11.2.8 The allowable deflection of flexural members of heaters under the action of frequent earthquake shall meet the requirements of Table 11.2.8. The allowable displacement at the top of framework columns of the heaters shall be less than 1/450 of total length of the columns.

Table 11.2.8 Allowable deflection of flexural members

Name of member	Allowable deflection
Girder of hanging boiler tube	$L/400$
Girder of main framework	$L/400$
Girder at bottom of convection chamber of cylindrical heater	$L/450$
Bottom beam of stack	$L/400$
Girder at bottom of heater	$L/360$
Purlins of operating shed	$L/200$
Base beam of fan at the top of heater	$L/400$
Other beams	$L/250$

Note: L is the span of bending member, for cantilever beam, take 2 times the overhang length.

11.2.9 For the heater structure which is higher than 150 m or has obvious weak story, the checking of elastic-plastic deformation of the structure under the action of rare earthquake shall be carried out, and the elastic-plastic floor displacement angle shall not be greater than 1/50.

11.3 Seismic measures

11.3.1 Where heater can not meet the requirements of seismic checking, reinforcement shall be provided for the members or connection joints, additional bracing members may be provided alternatively.

11.3.2 Where cylindrical heater body cannot meet the requirements of the seismic appraisal, seismic measures shall be taken according to the following requirements:

1 If the convection chamber is higher than 4 m and has no sub-framework, symmetrical diagonal bracings should be provided to laterally reinforce the framework columns of the convection chamber (Figure 11.3.2);

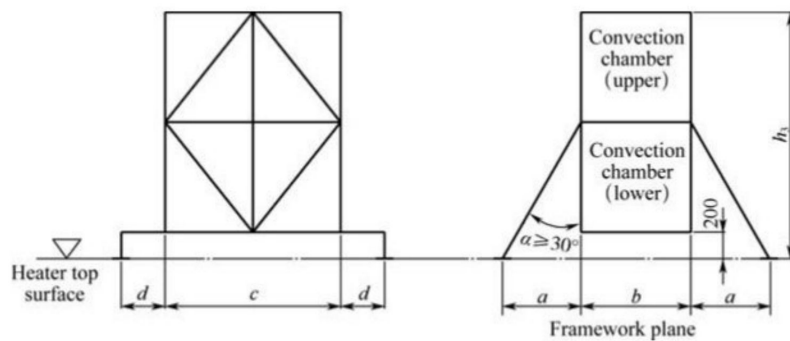

Figure 11.3.2 Diagonal bracings of convection chamber

2 Where a straight stack is provided on the top of the convection section, the top surface of the convection section shall be provided with horizontal bracings and the supporting members size shall not be less than angle steel 63×6;

3 Where the base of the stack on the top of the convection section is supported by a single beam, the beam ends shall be rigidly connected, and the size should not be less than H200×100;

4 Where the seismic precautionary intensity is 7 degree and greater, and the radiant tubes are supported on the upper part of the cylinder, downward longitudinal stiffener shall be evenly provided along the ring beam at the top of the cylinder, and the spacing between them should be 0.6m to 1.3m;

5 Where the diameter of cylinder of the radiation chamber is greater than 3.8m, and when the pedestal of the convection chamber does not coincide with the columns of the radiation chamber, the ring beam at the top of the radiation chamber should be reinforced by open web combined cross-section.

11.3.3 If vertical(box-type)heater body can not meet the requirements of seismic appraisal, seismic measures shall be taken according to the following requirements:

1 Structural diagonal bracings shall be provided in top of the heater. If single-leg angle steels are used, the size of angle steels should not be less than 75×6; if double-leg angle steels are used, the size of the angle steels should not be less than 63×6;

2 Where a stack is provided at the top of the heater, diagonal bracings should be provided between two support columns;

3 The joining beams between the columns of heater framework and the columns supporting the convection chamber should be reinforced using rigid connection;

4 Both ends of base beam that supports the stack at the top of the heater shall be reinforced using rigid connection;

5 Knee bracings should be provided between base columns of lateral walls of heater frame.

11.3.4 If the seismic appraisal shows that the horizontal heater body can not meet the requirements, seismic measures shall be provided according to the following requirements:

1 For the horizontal heater, the fixed saddle shall be fixed to the foundation using anchor bolts, and the sliding saddle shall be provided with lateral displacement restricts. At the fixed support, the quantity of anchor bolts shall not be less than 4, each of which is provided with double nuts;

2 If the saddle can not meet the requirements of seismic appraisal, additional ribs should be provided to reinforce the saddle.

11.3.5 If seismic appraisal shows that the overhead flue ducts can not meet the requirements, seismic measures shall be provided according to the following requirements:

1 The wall thickness of flue ducts shall not be less than 5mm;

2 Bearing structure shall be provided at compensation joints of the socket type flue ducts;

3 Limiting devices shall be provided at supports on either side of flue ducts.

11.3.6 The slenderness ratio of columns, width/thickness ratio of slabs of columns and beams, slenderness ratio of supporting members, width/thickness ratio of supporting slabs of steel structures of heaters should be in accordance with the relevant requirements of current national standard GB 50191 *Code for Seismic Design of Special Structures*.

11.3.7 Each anchor bolt at base columns of heater shall be provided with double nuts. If the requirements in Table 11.3.7 are met, seismic checking may be exempted.

Table 11.3.7 Quantity and diameter of anchor bolts at pedestal of each base column of heater

Heater type	Seismic precautionary intensity	Quantity and diameter of anchor bolts at pedestal of each base column of heaters with different thermal loads				
		2.3MW to 4.6MW	4.6MW to 7MW	7MW to 11.6MW	11.6MW to 18.6MW	>18.6MW
Cylindrical heater	7	2×M24	2×M30	2×M36	2×M42	2×M42
	8	2×M30	2×M36	2×M36	2×M42	2×M48
Box-type heater	7	4×M30	4×M36	4×M36	4×M42	4×M42
	8	4×M30	4×M36	4×M36	4×M42	4×M48

Note: The data for box-type heaters in the above table is based on the spacing between frames not greater than 4m.

11.3.8 Where flanged connection is used for the base of stack at the top of heater, the size of connecting bolts shall not be less than M16 and the spacing of bolts shall not be greater than 250mm. Where raised platform base type connection is used, the size of connecting bolts shall not be less than M24, the quantity of bolts shall not be less than 8; each connecting bolt shall be provided with double nuts.

11.3.9 The thickness of the annular plate at base of stack mounted on ground shall not be less than 14 mm, the size of anchor bolts shall not be less than M24, and the quantity of anchor bolts shall not be less than 8.

11.3.10 The anchor bolts of the support columns of heater shall be fixed with double nuts or provided with anti-loosening devices.

12 Air-cooled heat exchangers

12.1 General requirements

12.1.1 The seismic appraisal of horizontal, inclined-top, wet and dry-wet combined air-cooled heat exchangers (hereinafter referred to as "air coolers") shall comply with the requirements of this chapter.

12.1.2 The appearance of air coolers that require seismic appraisal shall meet the following requirements:

1 For the tube bundles of air coolers installed on ground where the seismic precautionary intensity is 7 degree and above or installed on load bearing structure, measures shall be taken to limit their lateral and vertical displacement;

2 The air cooler and the supporting structure shall be connected reliably. If they are connected by welds, the welds shall be continuous welds around the periphery of pedestal plate, and the height of fillet weld shall not be less than the thickness of the thinner part of two weldments;

3 Each column of the air cooler structure shall be provided with at least $4 \times M24$ anchor bolts and the thickness of the pedestal plate shall not be less than 20mm;

4 Fans, valves, pipelines and other ancillary equipment on the air cooler structure shall be reliably connected.

12.1.3 Where the design basic acceleration of ground motion is less than 0.20g, or the seismic precautionary intensity is less than 8 degree, the air cooler structure directly installed on the ground may not be subjected to seismic checking. Where the design basic seismic acceleration of ground motion is less than 0.40g, or the seismic precautionary intensity is less than 9 degree, the anchor bolts and thickness of pedestal plate of the columns of the air cooler structure may not be subjected to seismic checking.

12.1.4 The horizontal earthquake action on the air cooler structure along the direction of either main axis shall be calculated and seismic checking shall be carried out.

12.1.5 The seismic precautionary category of air coolers shall be category B stipulated in the current national standard GB 50453 *Standard for Classification of Seismic Protection of Buildings and Special Structures in Petrochemical Engineering*.

12.2 Earthquake effect and seismic checking

12.2.1 The basic natural vibration period of air coolers may be calculated according to the following requirements:

1 The basic natural vibration period of structures with diagonal bracings (Figure 12.2.1-1) may be taken as 0.2s.

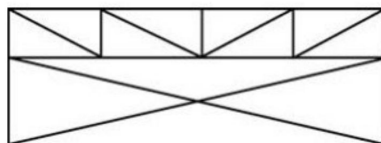

Figure 12.2.1-1 Structures with diagonal bracings

2 The basic natural vibration period of trussed structures (Figure 12.2.1-2) may be calculated according to following formulas:

$$T_1 = 0.18 \sqrt{m_k \sum_{i=1}^n \frac{S_i^2 l_i}{EA_i}} \quad (12.2.1-1)$$

$$m_k = m_f + m_1 + m_s + \frac{1}{4} m_j \quad (12.2.1-2)$$

Where:

T_1 —basic natural vibration period of an air cooler along the direction of checking(s);

m_k —equivalent mass concentrated at the top of structure of the air cooler(kg);

S_i —internal force of various members of trussed frame when a unit force is applied at the top of truss girder of the structure;

l_i —length of truss members(mm);

E —elastic modulus of the structure(MPa);

A_i —cross-sectional area of truss member(mm²);

m_f —mass of valves, fan pipelines and other auxiliary equipment of the air cooler(kg), which is taken as $0.15(m_s + m_j)$;

m_1 —equivalent mass of live load on the platform(kg), which is calculated based on $125\text{kg}/\text{m}^2$.

m_s —operating mass of tube bundle of the air cooler(kg);

m_j —mass of air cooler structure(kg).

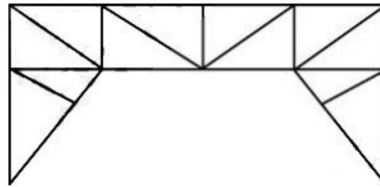

Figure 12.2.1-2 Trussed structure

3 The basic natural vibration period of a rigid frame or rigid-like frame structure(Figure 12.2.1-3 and Figure 12.2.1-4) may be calculated according to the following formula:

$$T_1 = 0.058 \sqrt{\frac{m_k h_c^3}{n_c EI}} \quad (12.2.1-3)$$

Where:

h_c —equivalent calculation height of columns of air cooler(mm);

n_c —sum of columns of air cooler structure;

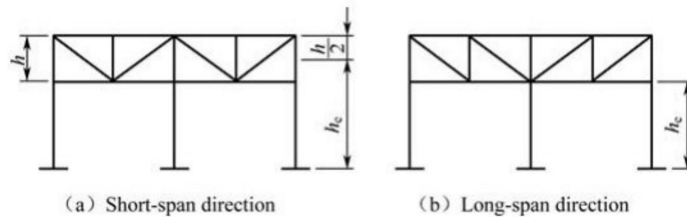

Figure 12.2.1-3 Rigid frame

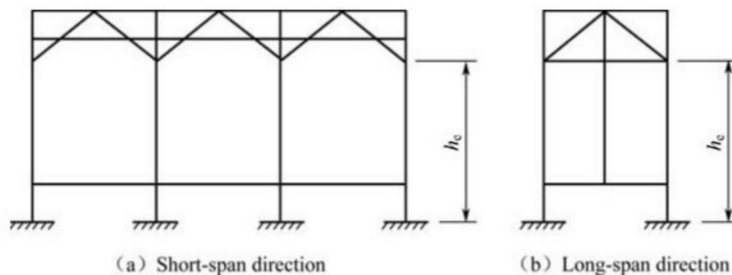

Figure 12.2.1-4 Rigid-like frame

I —moment of inertia of column cross-section in checking direction(mm^4).

12.2.2 The earthquake action on the air cooler structure shall be calculated according to the requirements of the current national standard GB 50011 *Code for Seismic Design of Buildings*. Where the air cooler is installed on supporting structure, the earthquake action effect shall be multiplied by an amplification coefficient of 1.5.

12.2.3 The seismic moment acted on the bottom of single column may be calculated according to following formula:

$$M_c = \frac{1}{2n_z} \gamma_{RE} F_H h_c \quad (12.2.3)$$

Where:

M_c —seismic moment acted on the bottom of single column($\text{N} \cdot \text{mm}$);

γ_{RE} —seismic adjustment coefficient of bearing capacity, which is taken as 0.75;

F_H —horizontal earthquake action on air cooler(N).

12.2.4 Wind moment applied on the air cooler may be calculated according to following formula:

1 The horizontal wind load may be calculated according to following formula:

$$F_w = \mu_s \mu_z W_0 A_s \quad (12.2.4-1)$$

Where:

F_w —horizontal wind load(N);

μ_s —shape coefficient, which is taken as 1.3;

μ_z —height variation factor of wind pressure, which is taken according to the current national standard GB 50009 *Load Code for the Design of Building Structures*;

W_0 —basic wind pressure(N/m^2);

A_s —wind projection area of air cooler(m^2).

2 The wind projection area of air cooler (Figure 12.2.4) may be calculated according to the following requirements:

1) For the structure of horizontal air cooler and wet-type air cooler, the wind projection area in two directions may be calculated according to following formulas:

$$A_s = B_2 H \quad (12.2.4-2)$$

$$A_s = LH \quad (12.2.4-3)$$

2) For the structure of inclined-top air cooler, the approximate wind projection area of the side gable wall may be calculated according to following formula:

$$A_s = \frac{B_1 + B_2}{2} H \quad (12.2.4-4)$$

3) For the structure of inclined-top air cooler, the wind projection area of frontage of tube bundle may be calculated according to following formula:

$$A_s = \frac{1}{2} LH \quad (12.2.4-5)$$

4) For the structure of combined type air cooler, the approximate wind projection area of the side gable wall may be calculated according to following formula:

$$A_s = \frac{B_1 + B_2}{2} H_1 + B_2 H_2 \quad (12.2.4-6)$$

5) For the structure of combined type air cooler, the wind projection area of frontage of tube bundle may be calculated according to following formula:

$$A_s = L \left(\frac{1}{2} H_1 + H_2 \right) \quad (12.2.4-7)$$

Where:

- B_2 —distance between columns in short-span direction(m);
- H —height of wind projection area(m);
- L —distance between columns in long-span direction(m);
- B_1 —spacing at top of inclined tube bundle box(m);
- H_1 —wind projection height of frontage at upper part(m);
- H_2 —wind projection height of frontage at lower part(m).

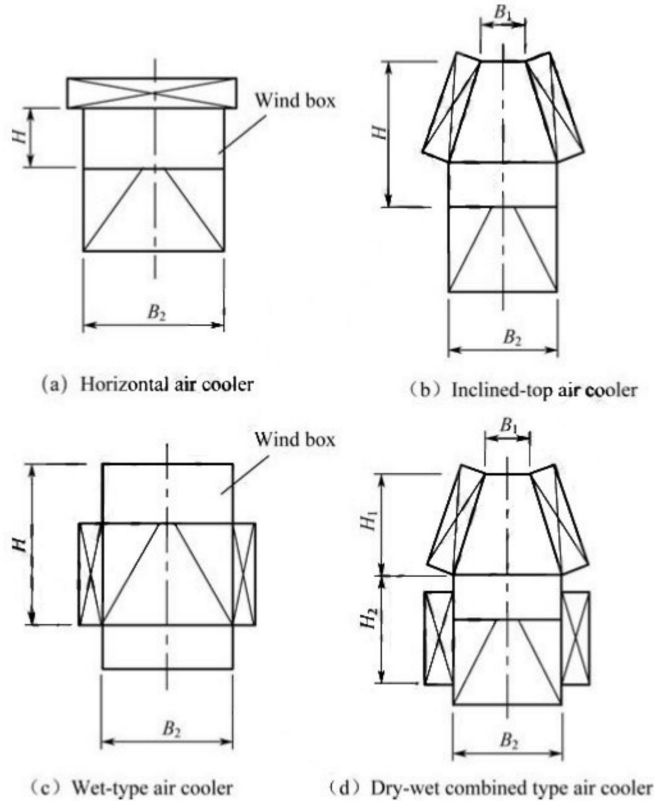

Figure 12.2.4 Wind projection area of air cooler

- 3 The wind moment applied on single column may be calculated according to following formula:

$$M_w = \frac{F_w h_c}{2n_z} \quad (12.2.4-8)$$

Where:

M_w —wind moment applied on single column(N·m).

12.2.5 The seismic checking of the structure of air cooler may be carried out according to the requirements of the current national standard GB 50011 *Code for Seismic Design of Buildings*.

12.2.6 In order to check the strength or stability of the structure of air cooler, earthquake action shall be combined with the following loads:

- 1 Dead load(weight of the structure, tube bundle and accessory equipment), which is taken as 100%;
- 2 Horizontal wind load, which is taken as 25%;
- 3 Live load on the platform, which is calculated based on 1200N/m².

12.2.7 The seismic checking of rigid framework or rigid-like frame structure shall be carried out according to the requirements regarding checking of compression-bending members stipulated in the

current national standard GB 50017 *Standard for Design of Steel Structure*:

- 1 Strength checking along the direction of application of bending moment;
- 2 Stability check of bending moment in the plane;
- 3 Stability check of bending moment of outside the plane.

12.2.8 The strength and stability check of trussed frames shall be carried out according to the requirements regarding checking of axially loaded members stipulated in the current national standard GB 50017 *Standard for Design of Steel Structures*.

12.2.9 The tensile force applied on diagonal bracings of structure with diagonal bracings may be calculated according to following formula:

$$N_c = \frac{\gamma_{RE} F_H + 0.25F_w}{n_k \cos\theta} \quad (12.2.9)$$

Where:

- N_c —tensile force applied on diagonal bracings(N);
- n_k —quantity of diagonal bracings in the checking direction;
- θ —horizontal angle of diagonal bracing(°).

12.2.10 The strength and stability of diagonal bracing shall be checked according to the requirements of the current national standard GB 50017 *Standard for Design of Steel Structures*.

12.2.11 The shear stress of welds on diagonal bracings shall be checked according to the requirements of the current national standard GB 50017 *Standard for Design of Steel Structures*. If the length of welds is greater than 100mm, the shear stress checking may be exempted.

12.2.12 The anchor bolts and pedestal plate of structures shall be checked according to the requirements of the current national standard GB 50017 *Standard for Design of Steel Structures*.

12.3 Seismic measures

12.3.1 Measures shall be taken to limit the lateral and vertical displacement of tube bundles of air cooler.

12.3.2 If the checking of strength and stability of columns of air cooler structures shows that they can not meet the requirements, additional diagonal bracings between columns shall be provided.

12.3.3 The air cooler structure and its supporting structure should be connected by using anchor bolts with anti-loosening devices. If they are connected by welding, the weldseams shall be continuous welds around the periphery of pedestal plate.

12.3.4 When the seismic checking shows that the base plate of pedestal of air cooler can not meet the requirements, ribbed plates may be provided or other reinforcing measures may be taken.

12.3.5 When the seismic checking shows that the anchor bolts can not meet the requirements, the pedestal plate may be welded with the connecting plate of the load bearing structure, or other reinforcing measures may be taken.

Explanation of wording in this standard

1 Words used for different degrees of strictness are explained as follows in order to mark the differences in implementing the requirements of this standard.

1) Words denoting a very strict or mandatory requirement:

"Must" is used for affirmation, "must not" for negation.

2) Words denoting a strict requirement under normal conditions:

"Shall" is used for affirmation, "shall not" for negation.

3) Words denoting a permission of a slight choice or an indication of the most suitable choice when conditions permit:

"Should" is used for affirmation, "should not" for negation.

4) "May" is used to express the option available, sometimes with the conditional permit.

2 "Shall comply with..." or "shall meet the requirements of..." is used in this standard to indicate that it is necessary to comply with the requirements stipulated in other relative standards and codes.

List of quoted standards

- GB 50009 *Load Code for the Design of Building Structures*
GB 50011 *Code for Seismic Design of Buildings*
GB 50017 *Standard for Design of Steel Structures*
GB 50191 *Code for Seismic Design of Special Structures*
GB 50453 *Standard for Classification of Seismic Protection of Buildings and Special Structures in Petrochemical Engineering*
GB/T 50761 *Standard for Seismic Design of Petrochemical Steel Equipments*
GB 12337 *Steel Spherical Tanks*
GB 18306 *Seismic Ground Motion Parameters Zonation Map of China*
NB/T 47041 *Vertical Vessels Supported by Skirt*